



BOZEMAN  
GUIDELINES FOR  
HISTORIC PRESERVATION  
& THE NEIGHBORHOOD  
CONSERVATION  
OVERLAY DISTRICT

JANUARY 17, 2006

Amended July 13, 2015



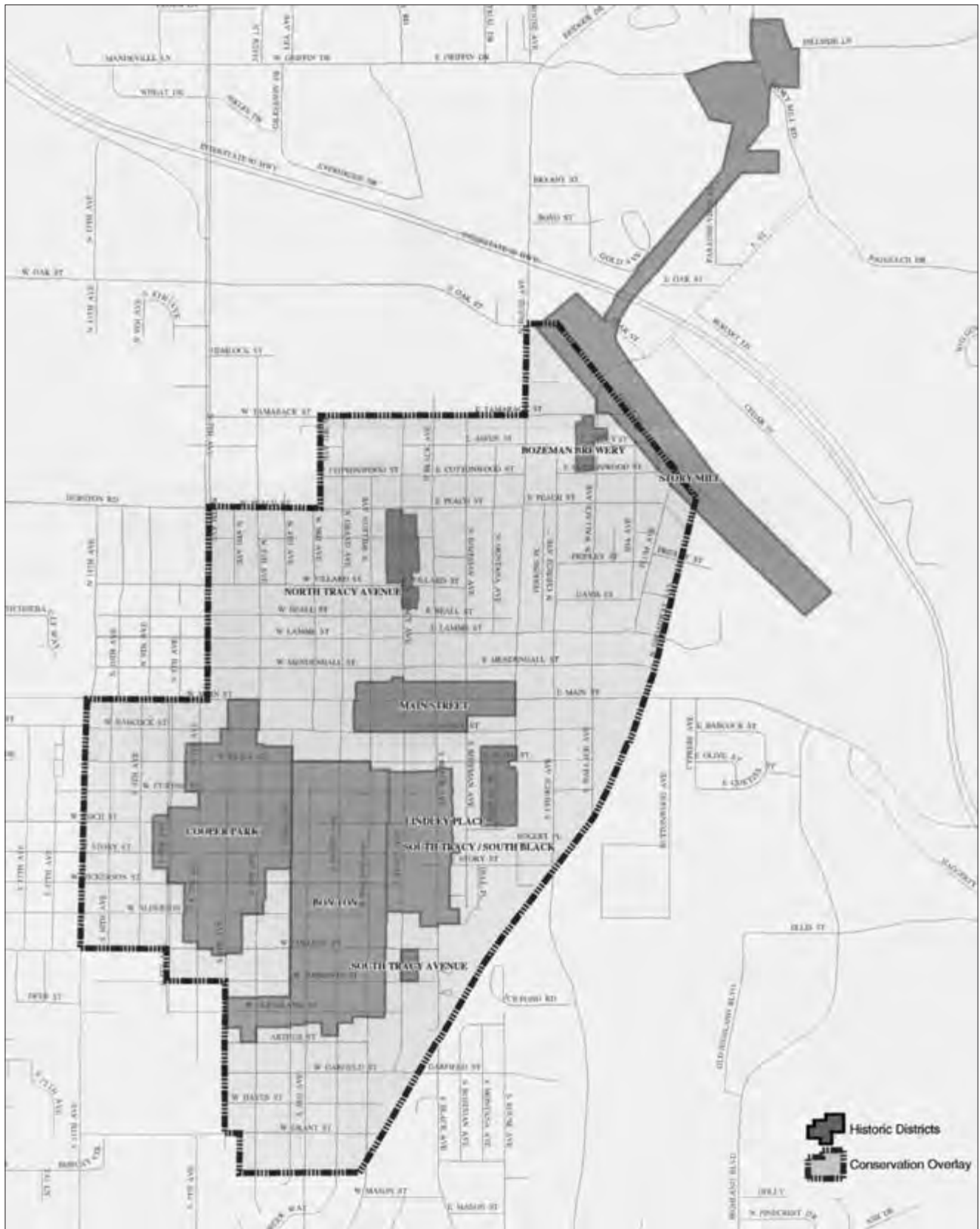

*On this map the City of Bozeman Overlay District is identified, as well as nine historic districts.*

## **Acknowledgments**

### **City of Bozeman**

**Mayor:** Andrew L. Cetraro, Jeff Krauss

**City Commission Members:** Sean Becker, Andrew L. Cetraro, Lee Hietala, Kaaren Jacobson, Steve Kirchhoff, Jeff Krauss, Jeff Rupp, Marcia Youngman

**City Staff:** Chris Kukulski, Andrew Epple, Chris Saunders, Allyson Bristol, Dave Skelton, Susan Kozub,

**Design Review Board Members:** Chairperson - Dawn Smith, Randy Carpenter, Scott Hedglin, Mel Howe, Brian Krueger, Michael Pentecost, Bill Rae, Elisa Ann Zavora

**Historic Preservation Advisory Board:** Chairman - Michael Neeley, City staff liason - Allyson Bristol, City Commision liason - Marcia Youngman, Warren Bauder, Clare Becker, Jane Davidson Klockman, Todd Larkin, Ben Lloyd, Bonnie Martin, Blake Maxwell, Maire O'Neill, Dede Taylor

**Zoning Commission:** Chairman - Ed Musser, Cliff Chisholm, Page Lutes, JP Pomnichowski

### **Special Thanks**

A special thank you to all the community members who participated in the workshops during the design guidelines process.

## **Consultants**

### **Winter & Company**

1265 Yellow Pine Avenue  
Boulder, CO 80304  
(303) 440-8445

with  
Ralph Johnson

# TABLE OF CONTENTS

## Introduction

<b>Part I: Overview</b>	<b>1</b>
A. Background of the Bozeman Design Guidelines Project	3
B. Preservation Goals for Bozeman	3
C. Basic Preservation Theory	4
D. Preservation Principles	6
E. Choosing an Approach Glossary	7
F. Planning a Preservation Project	8
<b>Part II: The Design Review System</b>	<b>9</b>
A. Bozeman Neighborhood Conservation Overlay District	9
B. Background of Design Guidelines	11
C. Determining Compliance with the Guidelines	11
D. Which Guidelines Apply?	12
E. Policies Underlying the Design Guidelines	14
F. Components of Design Guidelines	15
G. Applying for a Certificate of Appropriateness	16
<b>Chapter 1. Rehabilitation Guidelines For Historic Properties</b>	<b>19</b>
A. Character-Defining Features	21
B. Historic Building Materials	23
C. Individual Building Features	26
D. Rehabilitation of Historic Commercial Properties	32
E. Rehabilitation of Historic Residential Properties	36
F. Secondary Structures	41
G. Adaptive Re-Use	41
H. Historic Additions	41
<b>Chapter 2. Design Guidelines for all Properties</b>	<b>43</b>
A. Topography	45
B. Street Patterns	45
C. Alleys	46
D. Streetscapes	47
E. Landscape Design	48
F. Building Form	48
G. Solid-to-Void Ratio	49
H. Materials	50
I. Architectural Character	51
J. Parking	52
K. Buffers	53
L. Site Lighting	54
M. Utilities and Services	54

<b>Chapter 3. Guidelines for Residential Character Areas</b>	<b>55</b>
A. Hierarchy of Public and Private Space	57
B. Building Mass and Scale	58
C. Roof Forms	59
D. Secondary Structures	59
E. Multifamily	60
F. Fences and Retaining Walls	63
<b>Chapter 4. Guidelines for Commercial Character Areas</b>	<b>65</b>
A. Mass and Scale	67
B. Building and Roof Form	69
C. Building Setbacks	70
D. Horizontal Alignment	70
E. New Storefront Character	71
F. Parking Facilities	72
G. Site Furniture	73
H. Awnings and Canopies	73
I. Signs	74
<b>Subchapter 4B Guidelines For The B-3 Commercial Character Area</b>	<b>4B1-4B11</b>
<b>Chapter 5. District Specific Descriptions and Guidelines</b>	<b>77</b>
A. Northern Pacific/Story Mill Historic District	79
B. Bozeman Brewery Historic District	81
C. North Tracy Historic District	82
D. Main Street Historic District	83
E. Cooper Park Historic District	85
F. Lindley Place Historic District	86
G. Bon Ton Historic District	87
H. South Tracy/ South Black Historic District	88
I. South Tracy Historic District	91
<b>Appendix</b>	
Appendix A. The Secretary of the Interior’s Standards for Rehabilitation	App-1
Appendix B. Interpretation of Terms	App-2
Appendix C. Benefits of Historic Preservation	App-4
Appendix D. Preservation in Bozeman	App-7
A. Historic Overview of the City of Bozeman	
B. Architectural Styles	
Appendix E. Definitions	App-24

# INTRODUCTION



*Cooper Park Historic District*

## **In this Chapter:**

### **Part I: Overview**

- A. Background of Bozeman Design Guidelines Project
- B. Preservation Goals for Bozeman
- C. Basic Preservation Theory
- D. Preservation Principles
- E. Choosing an Approach Glossary
- F. Planning a Preservation Project

### **Part II: Design Review system**

- A. Bozeman Neighborhood Conservation Overlay District
- B. Background of Design Guidelines
- C. Determining Compliance with the Guidelines
- D. Which Guidelines Apply?
- E. Policies Underlying the Design Guidelines
- F. Components of Design Guidelines
- G. Applying for a Certificate of Appropriateness (COA)

This chapter introduces the design guidelines and describes how and when they should be used in the Bozeman community.

# INTRODUCTION

## Part I: Overview

Historic preservation and neighborhood conservation are well-established parts of city planning in Bozeman. Over the past decades, the community has initiated preservation initiatives to protect the many historic districts and older traditional neighborhoods that remain as reminders of the City’s heritage. While change continues to occur in response to varying community goals and economic conditions, preserving Bozeman’s heritage remains a primary goal of the community. These design guidelines are written for use by City Staff, property owners, residents and others to foster the preservation of historic residential and commercial districts and to maintain the traditional character of the broader Neighborhood Conservation Overlay District.

*The overall design goal for Bozeman is to preserve the integrity of its individual historic structures and the character of its streetscapes that are unique or irreplaceable assets to the City and its neighborhoods.*

## A. Background of the Bozeman Design Guidelines Project

The City of Bozeman resolved to create an interactive process for the Neighborhood Conservation Overlay District Design Guidelines project, through which the residents of Bozeman, the Historic Preservation Advisory Board (HPAB) and Design Review Board (DRB) expressed their concerns and expectations for the final product. The result has been a cooperative system of dialogue and values-clarification from which the City determined relevant concerns and goals for the District. This was accomplished through several public workshops. At these sessions, participants discussed positive attributes of the City’s historic neighborhoods and identified design issues that cause concern about future development. By completing exercises and discussions, the Bozeman residents took an active role in shaping the guidelines for the District.

## B. Preservation Goals for Bozeman

A primary design goal for Bozeman is to preserve the integrity of its individual historic structures and the character of its streetscapes in the Neighborhood Conservation Overlay District. To maintain the character of a historic building, design elements such as form, mass and materials should be considered in any alteration. The relationship each building has with other neighborhood design elements is also important, as well as the hierarchy of site elements, such as street trees, front yards, walkways and accessory structures.

## C. Basic Preservation Theory

### The Concept of Historic Significance

#### *What makes a property historically significant?*

In general, properties must be at least 50 years old before they can be evaluated for potential historic significance, although exceptions do exist when a more recent property clearly has historical value. A property may be significant for one or more of the following reasons:

- Association with events that contributed to the broad patterns of history, the lives of significant people or the understanding of a community's prehistory or history.
- Construction and design associated with distinctive characteristics of a building type, period or construction method.
- An example of an architect or master craftsman or an expression of particularly high artistic values.
- Integrity of location, design, setting, materials, workmanship, feeling and association that form a district.
- An established and familiar natural setting or visual feature of the community.

#### **Period of Significance**

In most cases, a property is significant because it represents or is associated with a particular period in its history. Frequently, this begins with the construction and continues through the peak of its early occupation. Building fabric and features that date from the period of significance typically contribute to the defining character of the structure.

Historic districts also have a period of significance. Specifically to each district, there is a more concise "period of significance" noted in the National Register nominations. Throughout each of these periods the historic districts have been witness to a countless number of buildings and additions which have become an integral part of the neighborhood. Conversely, several structures have been built or alterations have been made after this period which are generally considered non-contributing and may be considered for removal or replacement. In general keep this in mind:

## **Concept of Integrity**

A property also must have integrity, in that a sufficient percentage of the structure must date from the period of significance. The majority of the building's structural system and materials should date from the period of significance and its character-defining features also should remain intact. These may include architectural details such as dormers, porches, ornamental brackets, moldings and materials, as well as the overall mass and form of the building. These elements allow a building to be recognized as a product of its own time.

## **Alterations**

Many historic structures have experienced alterations over time, as design tastes changed or need for additional space occurred. In some cases, an owner would add a wing for a new bedroom, or to expand the kitchen. Early alterations typically were subordinate in scale and character to the main building and were often executed using materials that were similar to those in use historically.

Some early alterations may have taken on historic significance of their own. One constructed in a manner that is compatible with the original building and that is associated with the period of significance may merit preservation in its own right.

In contrast, more recent alterations usually have no historic significance. Some later additions detract from the character of the building and may obscure significant features, particularly enclosed porches. Removing such additions or alterations may be considered in a rehabilitation project.

This tradition of alterations is anticipated to continue. It is important, however, that new alterations be designed in such a manner that they preserve the historic character of the primary structure.

## D. Preservation Principles

The following preservation principles should be applied to all historic properties:

- **Respect the historic design character of the building.**  
Don't try to change its style or make it look older than its actual age. Confusing the character by mixing elements of different styles can weaken the appearance and historic quality of the structure.
- **Seek uses that are compatible with the historic character of the building.**  
Building uses that are closely related to the original use are preferred. Every reasonable effort should be made to provide a compatible use for the building that will require minimal alteration to the building and its site.

Property owners should consider the impacts that some changes in use would have upon their historic properties, since this may affect design considerations that are reviewed by the Department of Planning. Check the Unified Development Ordinance (UDO) to determine which uses are allowed.

Change in uses requiring the least alteration to significant elements are preferred. In some instances, however, a radical change in use may be necessary to keep the building in active service. In order to adapt a building to the proposed new use, the alterations may be too extreme and the proposed loss of historic building fabric would require a reassessment of a more appropriate use. Experience has shown that in most cases designs can be developed that respect the historic integrity of the building while also accommodating new functions. Note that more radical changes in use can make projects more expensive or result in the loss of significant features. Carefully evaluate the cost of alteration, as adaptation for a radical change may prove too costly or destroy too many significant features.

- **Protect and maintain significant features and stylistic elements.**  
Distinctive stylistic features or examples of skilled craftsmanship should be treated with sensitivity. The best preservation procedure is to maintain historic features from the outset to prevent intervention. Protection includes the maintenance of historic material through treatments such as rust removal, caulking, limited paint removal and reapplication of paint.
- **Preserve any existing original site features or original building materials and features.**  
Preserve original site features such as a rock retaining walls. Avoid removing or altering original materials and features. Preserve original doors, windows, porches and other architectural features.

- **Repair deteriorated historic features, and replace only those elements that cannot be repaired.**

Upgrade existing material, using recognized preservation methods whenever possible. If disassembly is necessary for repair or restoration, use methods that minimize damage to original materials and the replacement of original configuration.

## E. Choosing an Approach Glossary

Preservation projects may include a range of activities, such as maintenance of existing historic elements, repairs of deteriorated materials, the replacement of missing features and construction of new additions. When planning a preservation approach, consider the definitions of the following terms:

- **Preservation.** The act or process of applying measures to sustain the existing form, integrity and material of a building. Some work focuses on keeping a property in good working condition by repairing features as soon as deterioration becomes apparent, using procedures that retain the original character and finish of the features. Property owners are strongly encouraged to maintain properties in good condition.
- **Rehabilitation.** The process of returning a property to a state that makes a contemporary use possible while still preserving those portions or features of the property which are significant to its historical, architectural and cultural values. Rehabilitation may include a change in use of the building or additions.
- **Renovation.** The process of improving by repair, to revive. In renovation, the usefulness and appearance of the building is enhanced. The basic character and significant details of a building are respected and preserved, but some sympathetic alterations may also occur.
- **Restoration.** The process of reproducing the appearance of a building exactly as it looked at a particular moment in time. This may include the removal of later work or the replacement of missing historic features.
- **Remodeling.** The process of changing the historic design of a building. The appearance is altered by removing original details and by adding new features that are out of character with the original. Remodeling of an historic structure is inappropriate due to the loss of original fabric.
- **Reconstruction.** The process of rebuilding a structure that no longer exists exactly as it appeared historically.

## F. Planning a Preservation Project

The first step in planning a preservation project is to identify any character-defining features and materials of the structure. Retaining such details will greatly enhance the overall quality of the project. If they are in good condition, then selecting an appropriate treatment will provide for proper preservation. In making the selection, follow this sequence:

- **Preserve:** If a feature is intact and in good condition, maintain it as such.
- **Repair:** If the feature is deteriorated or damaged, repair it to its original condition.
- **Replace:** If it is not feasible to repair the feature, then replace it with one that is the same or similar in character (e.g., materials, detail, finish) to the original one. Replace only that portion which is beyond repair.
- **Reconstruct:** If the feature is missing entirely, reconstruct it from appropriate (photographic) evidence. (This treatment is only appropriate for small portions of a project, not the majority of the work.)
- **If a new feature or addition** is necessary, design it in such a way as to minimize the impact on original features.

In essence, the least level of intervention is preferred. By following this tenet, the highest degree of integrity will be maintained for the property.

## Part II: Design Review System

### A. Bozeman Neighborhood Conservation Overlay District

The Neighborhood Conservation Overlay District is an area that was created by the City of Bozeman to recognize the historic core of the Bozeman community. It encompasses Bozeman’s nine National Register of Historic Places historic districts, as well as the many individual National Register listings. Please see Chapter 5 for a detailed description of each historic district.

All proposed alterations (including demolition) to structures and sites within the area are subject to design review by the City of Bozeman Department of Planning and are subject to standards set forth in the City of Bozeman Unified Development Ordinance (UDO), in addition to these particular design guidelines.

As stated in the UDO, “the intent and purpose of the conservation district designation is to stimulate the restoration and rehabilitation of structures, and all other elements contributing to the character and fabric of established residential neighborhoods and commercial or industrial areas.”

Further, the ordinance states that while new construction is invited and encouraged, “primary emphasis is given to the preservation of existing buildings, provided the design of such new places enhances and contributes to the aesthetic character and function of the property and the surrounding neighborhood or area.”

The essential idea behind the Neighborhood Conservation Overlay District concept is to protect Bozeman against alteration and demolition that might damage the unique fabric created by the hundreds of important buildings and sites that make up the historic core of Bozeman.

#### ***How does the City of Bozeman administer proposed alterations to structures and sites located in the Neighborhood Conservation Overlay District?***

Exterior alterations, such as a new fence or a new addition, that occur within the Neighborhood Conservation Overlay District are largely administered through the City Historic Preservation Office, a division of the Bozeman Department of Planning and Community Development. The Historic Preservation Office and Administrative Design Review Staff will use this document, in addition to the standards set forth in the UDO, as a guide for determining the historical appropriateness of a proposed building alteration.

Generally, interior alterations, landscaping, painting, and minor repair with like materials are not under the jurisdiction of the City of Bozeman. However, it is important to note that the replacement or modification of features with a new type or material **does** require approval from the City. If the previous feature was constructed before the current UDO was enacted, the City may view the replacement construction as an opportunity to bring the element into code compliance.

Alteration: Any act or process, except repair and light construction that changes one or more of the architectural features of a structure or site, including, but not limited to, the erection, construction, reconstruction, relocation of, or addition to a structure.

Examples of Alteration:

- building addition
- new window(s)
- change in roof materials
- fence
- change in exterior siding materials

***My home is located within the Neighborhood Conservation Overlay District.***

***What procedures must I follow to alter my property?***

If a resident within the Neighborhood Conservation Overlay District intends to alter the exterior of their home, they must apply for a Certificate of Appropriateness, or **COA**, through the Department of Planning. The applicant is required to submit application material regarding the project, including a scaled site plan, elevation drawings, and photographs of the project location. Once an application is deemed complete, the design review process begins. A COA, as the name implies, is certification that the design of a project is appropriate for the historic neighborhood or area in which it is located. COA approval is required for any alteration (including sign or fence construction), demolition, or new construction within the Neighborhood Conservation Overlay District. Interior modifications to property within the District are not subject to COA review, unless the property is a National Register contributing structure that is frequented by the general public.

***What if I want to demolish, or move, a building on my property?***

The demolition and movement of structures within the Neighborhood Conservation Overlay District are considered an alteration and therefore are also subject to review by City Staff. Application for the demolition or removal of structures within the Neighborhood Conservation Overlay District will not be accepted without a comprehensive plan for the subsequent development of the property. This plan must be approved before a demolition or moving permit is issued. Generally, if the building has been determined to be historically significant, final authority for the demolition or movement shall rest with the City Commission.

***Where can I locate further information?***

The City of Bozeman provides information related to zoning and community development, including the *Bozeman 2020 Community Plan*. Find out more about local planning at: <http://www.bozeman.net/planning.html>

There are many online resources that can provide information related to Bozeman's Neighborhood Conservation Overlay District. Additional design standards such as "The Secretary of the Interior's Standards for Rehabilitation" can be located online at:

<http://www2cr.nps.gov/tps/standguide/index.htm>

The Montana State Historic Preservation Office (SHPO) is another excellent source for preservation information:

<http://www.his.state.mt.us/departments/shpo/index.html>

If the property is a "contributing" element within one of Bozeman's National Register historic districts, and it is income-producing, it may be eligible for preservation-related federal tax credits. More information can be located at:

<http://www2.cr.nps.gov/tps/tax/index.htm>

## B. Background of Design Guidelines

### What are Design Guidelines?

The guidelines convey general policies about the design of alterations to existing structures, additions, new construction and site work. However, they do not dictate solutions. Instead, they define a range of appropriate responses to a variety of specific design issues.

### Why have Design Guidelines?

The purpose of the guidelines and the review process through which they are administered is to promote preservation of the historic, cultural and architectural heritage of Bozeman. These resources are fragile and are vulnerable to inappropriate alteration and demolition. Recognizing this concern, Bozeman established these guidelines.

One purpose for these guidelines is to inform the community about the design policies the city holds for the overlay district. They indicate an approach to design that will help provide information that property owners may use to make decisions about their buildings and to maintain their historic character. The guidelines also provide Bozeman a basis for making informed, consistent decisions about design.

The design guidelines provide a basis for making consistent decisions about the treatment of historic resources. They also serve as educational and planning tools for property owners and their design professionals who seek to make improvements that may affect historic resources.

While the design guidelines are written for use by the layperson to plan improvements, property owners are strongly encouraged to enlist the assistance of qualified design and planning professionals, including architects and preservation consultants.

Known for its ongoing preservation efforts, the Bozeman Neighborhood Conservation Overlay District is foreseeing continued investment in the area, including renovation, additions to existing buildings and infill construction. Therefore, a wide range of construction projects are anticipated and the pressure on the historic district's integrity is increased, as is the need for guidelines.

## C. Determining Compliance with the Guidelines

The Department of Planning and Community Development will administer the guidelines. In doing so, they will consider how each proposed project meets the guidelines and how the proposed work would therefore help to accomplish the design goals set forth in this document and in the Unified Development Ordinance (UDO).

A project may fall into a special review category because of its size or design complexity. In this case the Historic Preservation Advisory Board (HPAB) and/or the Design Review Board (DRB) may be consulted to advise City Staff on the appropriateness of the project design.

It is important to note that the City has the right to update, change and revise previously assigned project types. For example, the Montana Historical & Architectural Inventory files may assign a property a non-contributing status; after reassessing the building, it may in fact be reassigned as a contributing property to the district. Any changes to the building would then need to follow the guidelines for that project type.

## **D. Which guidelines apply?**

The guidelines apply to all work subject to design review in the Neighborhood Conservation Overlay District, as well as to individual National Register properties that may be located elsewhere in the City. However, different chapters will apply, depending upon the type of property. Those that have historic significance will have guidelines for preservation to be considered, along with other general standards, while more general guidelines for compatibility apply to a new building. In addition, some guidelines vary by building type. Those for commercial buildings, for example, are different from those for residences. The following is a general overview of different project types and their related guidelines:

### ***1. Contributing Property***

A building that is identified as having significance and contributing to the character of a designated historic district is considered “contributing.” These are identified on the Montana Historical & Architectural Inventory files, but in some cases, significance may be determined at the time that an application for approval is submitted. For these properties, preservation of the key character-defining features is the objective. Focus is on the rehabilitation guideline, design guidelines for all properties, and other more context-sensitive district guidelines.

### ***2. Non-Contributing Property***

A building found within a designated historic district, but which does not contribute to the significance of the district, is considered “non-contributing.” This may be a newer building that has not taken on significance, or it may be an older one that has been so substantially altered that it lacks integrity as a historic resource. For these properties, the guidelines for all properties apply, which address how buildings may fit within a neighborhood. In addition, guidelines for the building type apply, as well as those in the special chapter for the historic district in which the property lies. Rehabilitation guidelines do not apply. The objective is to assure that if the property is altered, the result would be compatible with the historic context. Preservation of features on the building itself is not a priority. It is important to note that with appropriate rehabilitation, a building may move to a “contributing” status. The Historic Preservation Office recommends all property owners consider this approach in alteration projects.

### ***3. National Register Individual Listing***

A property that, on its own, has sufficient significance to be considered a historic resource may be designated individually on the National Register. For these, preservation is the objective, and the guidelines for rehabilitation are to be applied. The design guidelines for all properties would also apply.

TYPE OF WORK	CHAPTER TO USE						
	Introduction	Chapter 1. Rehabilitation Guidelines for	Chapter 2. Design Guidelines for all Properties	Chapter 3. Guidelines for Residential Areas	Chapter 4. Guidelines for Commercial Areas	Chapter 5. District Specific Descriptions and Guidelines	Appendix
1. Alteration of a “contributing property” in an Historic District	<input checked="" type="checkbox"/>	<input checked="" type="checkbox"/>	<input checked="" type="checkbox"/>	<input checked="" type="checkbox"/> If Residential	<input checked="" type="checkbox"/> If Commercial	<input checked="" type="checkbox"/>	<input checked="" type="checkbox"/>
2. Work on a “non-contributing” property in an Historic District	<input checked="" type="checkbox"/>		<input checked="" type="checkbox"/>	<input checked="" type="checkbox"/> If Residential	<input checked="" type="checkbox"/> If Commercial	<input checked="" type="checkbox"/>	<input checked="" type="checkbox"/>
3. Work on an “individually listed National Register Property” in the Neighborhood Conservation Overlay District	<input checked="" type="checkbox"/>	<input checked="" type="checkbox"/>	<input checked="" type="checkbox"/>	<input checked="" type="checkbox"/> If Residential	<input checked="" type="checkbox"/> If Commercial	<input checked="" type="checkbox"/>	<input checked="" type="checkbox"/>
4. Work on a “historically significant property” in the Neighborhood Conservation Overlay District, but outside of an Historic District	<input checked="" type="checkbox"/>	<input checked="" type="checkbox"/>	<input checked="" type="checkbox"/>	<input checked="" type="checkbox"/> If Residential	<input checked="" type="checkbox"/> If Commercial		<input checked="" type="checkbox"/>
5. Work on a “non-historically significant” property in the Neighborhood Conservation Overlay District but outside of an Historic District	<input checked="" type="checkbox"/>		<input checked="" type="checkbox"/>	<input checked="" type="checkbox"/> If Residential	<input checked="" type="checkbox"/> If Commercial		<input checked="" type="checkbox"/>
6. New infill and construction in the Neighborhood Conservation Overlay District, but outside an Historic District	<input checked="" type="checkbox"/>		<input checked="" type="checkbox"/>	<input checked="" type="checkbox"/> If Residential Zone District	<input checked="" type="checkbox"/> If Commercial Zone District		<input checked="" type="checkbox"/>
7. New infill and construction in An Historic District*	<input checked="" type="checkbox"/>		<input checked="" type="checkbox"/>	<input checked="" type="checkbox"/> If Residential	<input checked="" type="checkbox"/> If Commercial	<input checked="" type="checkbox"/>	<input checked="" type="checkbox"/>

Note: A blank box indicates that the chapter does not apply.

\*Chapter 2, Chapter 3 and Chapter 4 guidelines will be applied more rigorously on projects in these districts.

#### ***4. Historically Significant Property in the Conservation Overlay***

Other older buildings are found within the Conservation Overlay, but outside of any historic district. They are generally isolated buildings, in the context of newer structures, but sometimes they exist in a small grouping. These may be identified at the time of application for COA approval. The conservation of the overall character of the building is the focus. The rehabilitation guidelines are therefore applied with some flexibility. Focus is on maintaining the general form, character and materials, but more latitude in alterations is available. When such a building is in a context of similar construction, the rehabilitation guidelines will be applied more rigorously.

#### ***5. Non-historically Significant Property in the Conservation Overlay***

These are more recent properties, or older ones that are substantially altered, which lie within the Conservation Overlay, but outside of any historic district. For these, the design guidelines for all properties will apply, as well as those for specific building types (commercial or residential).

#### ***6. New Infill and Construction***

For new projects within a historic district, the design guidelines for all properties will apply, as well as those for specific character areas and historic districts. The guidelines will be applied more rigorously in this case.

For new infill projects within the Conservation Overlay, but outside of any historic district, the design guidelines for all properties will apply, as well as those for specific character areas.

Please see the table on page 13 for a diagram of what guidelines apply to a project.

### **E. Policies underlying the design guidelines**

The preservation principles outlined in Appendix C, as well as the following policies, should be considered when applying the design guidelines to historic properties in Bozeman.

#### **The Secretary of the Interior's Standards for the Rehabilitation of Historic Properties**

The design guidelines incorporate principles set out in *The Secretary of the Interior's Standards for the Treatment of Historic Properties with Guidelines for Preserving, Rehabilitating, Restoring and Reconstructing Historic Buildings*, which are listed in Appendix B. These are a widely accepted set of general rehabilitation standards established by the National Park Service. These standards are policies that normally serve as a basis for more detailed rehabilitation guidelines. The City of Bozeman's Unified Development Ordinance has adopted *The Secretary of the Interior's Standards* as a basis for its standards for a COA. It is the intent of this document to be compatible with the *Standards*, while expanding on those basic preservation principles as they apply in Bozeman.

## A. Character-Defining Features

### Policy:

Historic features, including original materials, architectural details, window and door openings, contribute to the character of a structure and should be preserved when feasible. Continued maintenance is the best preservation method.

### Guidelines

- 1. Protect and maintain significant stylistic features.**
  - The best preservation procedure is to maintain historic features from the outset so that intervention is not required.
  - Preserve character-defining features. Then, repair only those features that are deteriorated. Finally, replace only those features that are beyond repair.



*Protect and maintain significant stylistic features, such as this window detail.*

*Detail of Design Guideline Components*

## F. Components of Design Guidelines

Each chapter of the design guidelines contains the following components:

### Design Element

The first is the **design element** category (e.g., streetscape elements, site planning, building materials and secondary structures) under which the design guideline falls.

### Policy Statement

Second is a **policy statement** explaining the Bozeman Department of Planning's basic approach to treatment of the design element. This statement provides the basis for the more detailed design guidelines that follow underneath. In cases where special conditions in a specific project are such that the detailed design guidelines do not appear to address the situation, this general policy statement shall serve as the basis for determining the appropriateness of the proposed work. Policy statements are shown as large typeface statements.

### Design Guidelines

Third is the **design guideline statement** itself, which is typically performance-oriented, describing a desired design treatment. The specific design guidelines are numbered and presented in **bold face** statements under each policy statement.

### Additional Information

The design guideline statement is followed by supplementary information that is treated as sub-points of the guideline. These sub-points may include additional requirements, or may provide an expanded explanation. These sub-points are listed as bulleted (•) statements.

## **Illustrations**

Design guidelines are further explained through the use of photographs and illustrations. Examples given should not be considered the only appropriate options, but rather used as a guiding reference. In most instances, there are numerous possible solutions that meet the intention of the design guidelines, as well as the needs of the property owner.

In order to help the reader determine design approaches that are appropriate, many of the illustrations are marked with either a ✓ or an ✘. Those illustrations marked with a ✓ are considered appropriate solutions to the design issue, whereas those illustrations marked with an ✘ are not appropriate.

## **G. Applying for a Certificate of Appropriateness (COA)**

A Certificate of Appropriateness, as its name implies, is a certification that the design of a project is appropriate within the neighborhood or area in which it is located. It is required for any alteration, demolition or new construction in the Neighborhood Conservation Overlay District as defined in the UDO. Use the following steps for recommendations on how to proceed with a COA application:

### **Step 1. Consider Professional Design Assistance.**

Property owners are strongly encouraged to engage licensed architects and other design and planning professionals to assist them in developing their concepts. Doing so may facilitate a quick review process.

### **Step 2. Check Other City Regulations.**

The guidelines supplement other adopted Bozeman ordinances. The Department of Planning can provide information about these regulations, which also may affect the design character of a project. Examples include:

- The Bozeman Unified Development Ordinance
- The City of Bozeman 2020 Community Plan
- Design Objectives Plan

### **Step 3. Become Familiar with the Design Guidelines.**

Review the basic organization of this guidelines document and determine which chapter(s) will apply to a project. The chart listed on page 13 is a great illustration to help see which chapters are applicable.

### **Step 4. Review the Site Context.**

Consider immediately adjacent properties and also the surrounding character of the project site. Understanding the desired character of the area is vital to the development of an appropriate design.

**Step 5. Develop a Design Concept Using the Guidelines.**

The guidelines form the basis for the city’s design review decisions. Following the guidelines from the outset of the project will facilitate a smooth process.

**Step 6. Preliminary Review (optional).**

Prepare materials for preliminary review by the Historic Preservation Office prior to creating drawings for final submittal. This step is highly recommended for new construction, accessory buildings and major alterations and additions. Even if preliminary material are not created, an initial meeting with City Staff is encouraged before an application is submitted.

**Step 7. Prepare and Submit a Complete Application Packet for Formal Review.**

A complete application packet should be prepared, which includes the contents that are listed on the checklist form for a Certificate of Appropriateness, available at the Department of Planning and Community Development. A clear presentation of the proposed project to the City is necessary to obtain a COA. The presentation should focus on how the proposed project complies with these design guidelines and the standards set forth in the UDO. (See section 18.78.090 of the UDO.)



## CHAPTER 1

# REHABILITATION GUIDELINES FOR HISTORIC PROPERTIES



*Original architectural details shall be preserved during rehabilitation.*

## In this Chapter:

- A. Character-Defining Features
- B. Historic Building Materials
- C. Individual Building Features
- D. Rehabilitation of Historic Commercial Properties
- E. Rehabilitation of Historic Residential Properties
- F. Secondary Structures
- G. Adaptive Re-Use
- H. Historic Additions

This chapter focuses on rehabilitation guidelines for historic buildings. The guidelines are divided into sections discussing the overall character-defining features, the materiality of those features and the individual building features. Guidelines also address specific issues in regards to historic residential and commercial building types, including additions.



*Before*



*After*

*By following the design guidelines presented in this document a homeowner can reasonably expect results similar to the before and after conditions shown here.*

# CHAPTER 1

## REHABILITATION GUIDELINES FOR HISTORIC PROPERTIES

### Design Guidelines:

#### A. Character-Defining Features

##### Policy:

##### *Preserve*

Historic features, including original materials, architectural details and window and door openings contribute to the character of a structure and are referred to as character-defining features. They are often closely associated with specific architectural styles. They should be preserved when feasible. Continued maintenance is the best preservation method.

##### Guidelines:

- 1. Preserve and maintain significant stylistic and architectural features.**
  - Porches, turned columns, brackets, exposed rafter tails and jigsaw ornaments, if historic, are examples of architectural features that should not be removed or altered.
  - The best preservation procedure is to maintain historic features from the outset so that intervention is not required. Employ preventive measures such as rust removal, caulking, limited paint removal and reapplication of paint. These should not harm the historic materials.
  - Maintain character-defining features.
  - Do not remove or alter architectural details that are in good condition or that can be repaired.
- 2. Avoid adding elements or details that were not part of the original building.**
  - For example, details such as decorative millwork or shingles should not be added to a building if they were not an original feature of that structure.
- 3. Protect architectural details from moisture accumulation that may cause damage.**
  - Regularly check details that have surfaces which can hold moisture for long periods of time.



*Historic features, including original materials, architectural details and window and door openings contribute to the character of a structure and are referred to as character-defining features.*



*Details such as these should be preserved in order to avoid the need for replacement in the future.*



*Protect and maintain significant stylistic features, such as these porches, roof lines and window details.*



*Before: A deteriorated railing should be repaired, rather than replaced.*



*After: A successful preservation effort will result in a product shown in the example above.*

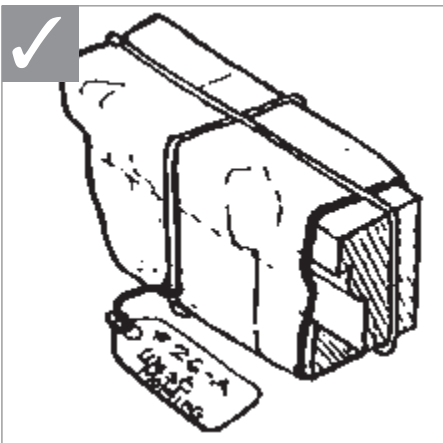

*When disassembly of a historic feature is required in a restoration procedure, document its location so that it may be repositioned accurately.*

**Policy:**

***Repair***

In some cases, original architectural details may be deteriorated. Horizontal surfaces such as chimney caps and window sills are likely to show the most deterioration because they are more exposed to weather. When deterioration occurs, repair the material and any other related problems. It is also important to recognize that all details weather over time and that a scarred finish does not represent an inferior material, but simply reflects the age of the building. Therefore, preserving original materials and features that show signs of wear is preferred to replacing them.

**Guidelines:**

**4. Repair only those features that are deteriorated.**

- Patch, piece-in, splice, consolidate or otherwise upgrade existing materials, using recognized preservation methods.
- Isolated areas of damage may be stabilized or fixed using consolidants. Epoxies and resins may be considered for wood repair.
- Removing damaged features that can be repaired is not appropriate.
- Protect features that are adjacent to the area being worked on.

**5. When disassembly of a historic element is necessary for its restoration, use methods that minimize damage to the original materials.**

- When disassembly of a historic feature is required during restoration, document its location so it may be repositioned accurately. Always devise methods of replacing disassembled details in their original configuration.

**6. Use technical procedures for cleaning, refinishing and repairing architectural details that will maintain the original finish.**

- Consult with the City of Bozeman for techniques that are generally considered appropriate.
- When choosing preservation treatments, use the gentlest means possible that will achieve the desired results.
- Employ treatments such as rust removal, caulking, limited paint removal and reapplication of paint or stain.

**Policy:**

***Replace***

While restoration of the original feature is the preferred alternative, in-kind replacement is also an option. In the event replacement is necessary, the new material should match that being replaced in design, color, texture and other visual qualities. Replacement should occur only if the existing historic material is beyond repair.

**Guidelines:**

7. **Replacement of missing or deteriorated architectural elements should be accurate.**
  - The design should be substantiated by physical or pictorial evidence to avoid creating a misrepresentation of the building's history.
  - Use the same kind of material as the original when feasible. However, a substitute material may be acceptable if the size, shape, texture and finish conveys the visual appearance of the original.
  
8. **When reconstruction of an element is impossible, develop a new design that is a simplified interpretation of it.**
  - This is appropriate when inadequate information exists to allow for an accurate reconstruction.
  - The new element should be similar to comparable features in general size, shape, texture, material and finish.



*Replace missing original details in kind.*

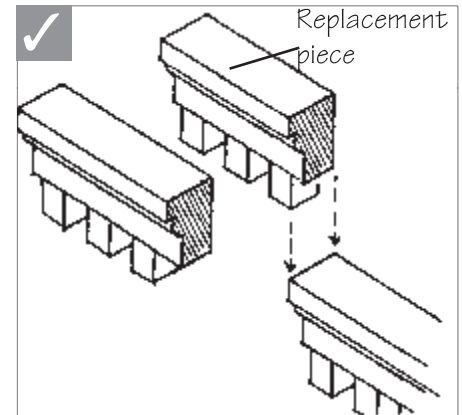

*Where replacement of an element is required, remove only those portions that are deteriorated beyond repair.*

## B. Historic Building Materials

**Policy:**

Primary historic building materials should be preserved in place whenever feasible. When the material is damaged, then limited replacement which matches the original, should be considered. Primary historic building materials should never be covered or subjected to harsh cleaning treatments.

Refer to the city for an appropriate material resources for the rehabilitation of historic properties.

**Guidelines:**

1. **Preserve original building materials.**
  - Avoid removing siding that is in good condition or that can be repaired in place.
  - Remove only siding which is deteriorated, and must be replaced.
  - Masonry features that define the overall historic character, such as walls, cornices, pediments, steps and foundations, should be preserved.
  - Avoid rebuilding a major portion of exterior masonry walls that could be repaired. Reconstruction may result in a building which is no longer historic.
  
2. **Protect wood features from deterioration.**
  - Provide proper drainage and ventilation to minimize rot.
  - Maintain protective coatings to retard drying and ultraviolet damage. If the building was painted originally, it should remain painted.



*Protect wood siding and other wood surfaces with a painted finish.*

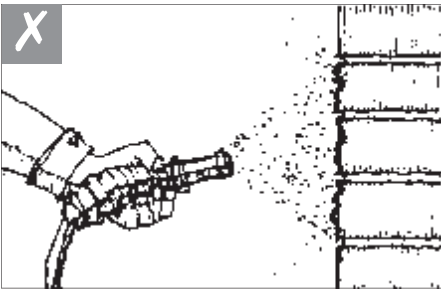

*Use approved technical procedures for cleaning, refinishing and repairing historic materials. Harsh cleaning methods, such as sandblasting, can damage the historic materials and change their appearance.*



*When reconstruction of an element is impossible, develop a new design that is a simplified interpretation of it.*



*Do not remove damaged materials that can be repaired. In this case, loose shingles may be re-secured while missing ones may be replaced.*

3. **Plan repainting carefully.**
  - Always prepare a good substrate. Remove damaged or deteriorated paint only to the next intact layer, using the gentlest means possible, prior to painting.
  - Use compatible paints. Some latex paints will not bond well to earlier oil-based paints without a primer coat.
4. **Brick or stone that was not painted historically should not be painted.**
  - Masonry naturally has a water-protective layer, or patina, to protect it from the elements. Painting masonry walls can seal in moisture already in the masonry; thereby not allowing it to breathe and causing extensive damage over the years.
5. **Repair deteriorated primary building materials by patching, piecing-in, consolidating or otherwise reinforcing the material.**
  - Avoid the removal of damaged materials that can be repaired.
  - Isolated areas of damage may be stabilized or fixed, using consolidants. Epoxies and resins may be considered for wood repair and special masonry repair components also may be used.
6. **Repoint mortar joints where there is evidence of deterioration.**
  - Duplicate the old mortar in strength, composition, color and texture.
  - Avoid using mortar with a high portland cement content, which will be substantially harder than the original.
  - Duplicate the mortar joints in width and profile.
7. **Use the gentlest means possible to clean the surface of a structure.**
  - Perform a test patch to determine that the cleaning method will cause no damage to the material surface. Many procedures can actually have an unanticipated negative effect upon building materials and result in accelerated deterioration or a loss of character.
  - Harsh cleaning methods, such as sandblasting, can damage the historic materials, changing their appearance. Such procedures are inappropriate.
  - If cleaning is appropriate, a low pressure water wash is preferred. Chemical cleaning may be considered if a test patch is first reviewed and negative effects are not found.
8. **Match the original material in composition, scale and finish when replacing materials on primary surfaces.**
  - If the original material is wood clapboard, for example, then the replacement material should be wood as well. It should match the original in size, the amount of exposed lap and in finish.
  - Replace only the amount required. If a few boards are damaged beyond repair, then only they should be replaced, not the entire wall.

**9. Do not use synthetic materials, such as aluminum or vinyl siding or panelized brick, as replacements for primary building materials.**

- In some instances, substitute materials may be used for replacing architectural details, but doing so is not encouraged. If it is necessary to use a new material, such as a fiberglass column, the style and detail should match that of the historic model.
- Primary building materials, such as wood siding and brick, should not be replaced with synthetic materials.
- Modular materials should not be used as replacement materials. Synthetic stucco and panelized brick, for example, are inappropriate.



*Commence with building cleaning after any repointing has completely cured.*

**10. Covering original building materials with new materials is inappropriate.**

- Vinyl siding, aluminum siding and new stucco are inappropriate on historic buildings. Other imitation materials that are designed to look like wood or masonry siding, but that are fabricated from other materials, are also inappropriate.
- If a property already has a non-historic building material covering the original, it is not appropriate to add another layer of new material, which would further obscure the original.

**11. Consider removing later covering materials that have not achieved historic significance.**

- Once the non-historic siding is removed, repair the original, underlying material.
- If a house has a stucco finish, removing the covering may be difficult, and may not be desirable. Test the stucco to assure that the original material underneath will not be damaged.



*Consider removing later covering materials that have not achieved historic significance. Compare the left photo with the photo on the right, after the synthetic siding was removed. Note how the lap dimensions on the original siding are much smaller.*





*If stucco covers original siding, then its removal is encouraged.*



*Repair wood features by patching or piecing-in new wood elements that match the original.*



*Protect and maintain the stylistic features and proportions of a historic window opening.*

## C. Individual Building Features

### Windows

#### Policy:

The character-defining features of an historic window and its distinct materials and placement should be preserved. In addition, a new window should be in character with the historic building. This is especially important on primary facades.

#### Guidelines

- 1. Preserve the functional and decorative features of a historic window.**
  - Features important to the character of a window include its frame, sash, muntins, mullions, glazing, sills, heads, jambs, moldings, operation and groupings of windows. Repair frames and sashes rather than replacing them, whenever conditions permit.
  - Window awnings and shutters are appropriate in limited circumstances. They are only appropriate on specific architectural styles and commercial building types. Shutters were found on colonial style buildings.
- 2. Preserve the position, number and arrangement of historic windows in a building wall.**
  - Enclosing a historic window opening in a key character-defining facade is inappropriate, as is adding a new window opening. This is especially important on primary facades where the historic ratio of solid-to-void is a character-defining feature.
  - Greater flexibility in installing new windows may be considered on rear walls.
- 3. Preserve the size and proportion of a historic window opening.**
  - Reducing an original opening to accommodate a smaller window or increasing it to receive a larger window is inappropriate.
- 4. Preserve the historic ratio of window openings to solid wall on a primary facade.**
  - Significantly increasing the amount of glass on a character-defining facade will negatively affect the integrity of the structure.
- 5. Match a replacement window to the original in its design.**
  - If the original is double-hung, then the replacement window should also be double-hung, or at a minimum, appear to be so. Match the replacement also in the number and position of glass panes.
  - Matching the original design is particularly important on key character-defining facades.

**6. In a replacement window, use materials that appear similar to the original.**

- Using the same material as the original is preferred, especially on character-defining facades. However, a substitute material may be considered if the appearance of the window components will match those of the original in dimension, profile and finish.

**7. Match, as closely as possible, the profile of the sash and its components to that of the original window.**

- A historic wood window has a complex profile. Within the window's casing, the sash steps back to the plane of the glazing (glass) in several increments. These increments, which individually only measure in eighths or quarters of inches, are important details. They distinguish the actual window from the surrounding plane of the wall.

**8. Use a storm window to enhance energy conservation rather than replace a historic window.**

- Install a storm window on the interior, when feasible. This will allow the character of the original window to be seen from the public way.
- If a storm window is to be installed on the exterior, match the sash design of the original windows. A metal storm window may be appropriate if the frame matches the proportions and profiles of the original window. It should fit tightly within the window opening without the need for sub-frames or panning around the perimeter. Match the color of the storm window sash with the color of the window frame; do not use an anodized or a milled (a silvery metallic) finish. Finally, set the sash of the storm window back from the plane of the wall surface as far as possible.

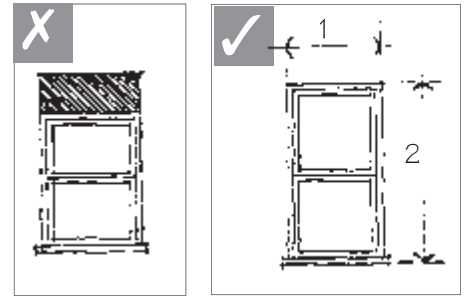

*Protect and maintain stylistic features and proportions of a historic window opening.*



*Preserving the proportions of a historic structure helps ensure continuity within a district.*

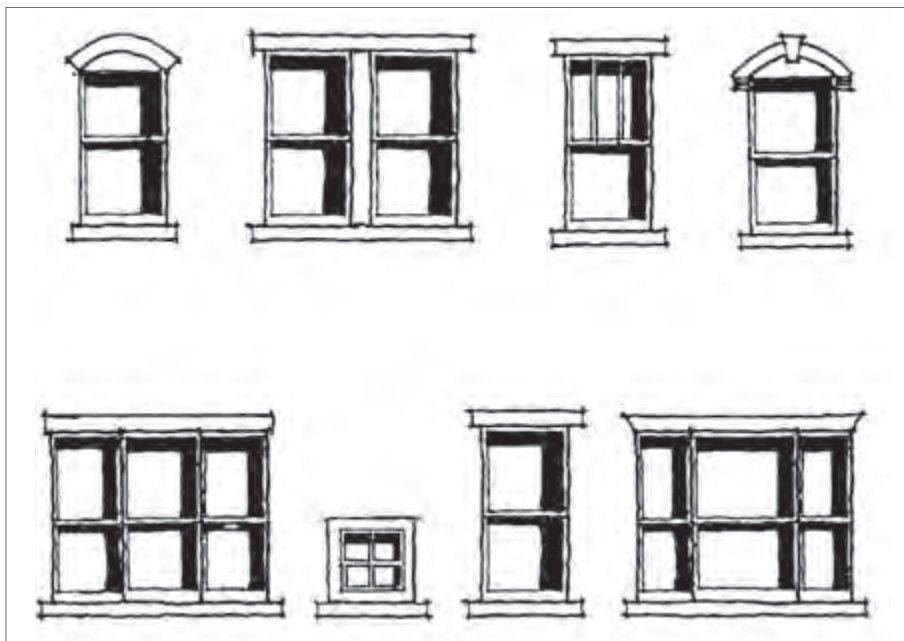

*Typical primary window types seen on historic structures.*

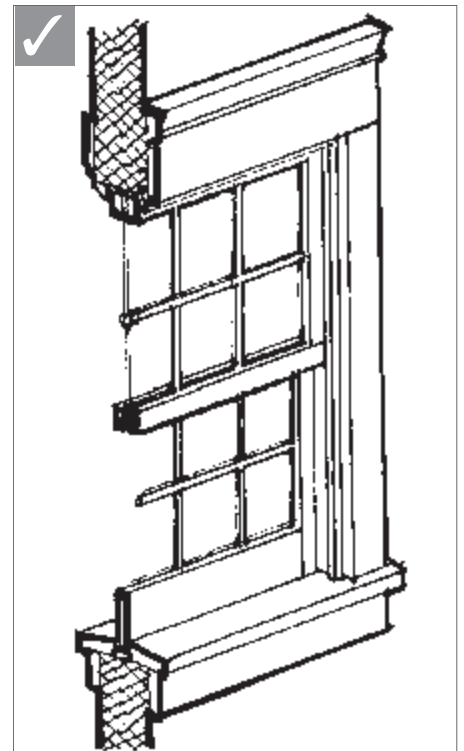

*The appearance of the window components should match those of the original in dimension, profile and finish.*



*Preserve the decorative and functional features of a primary door.*

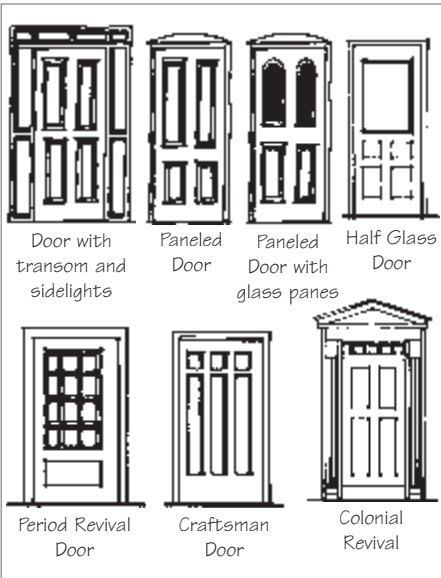

*Typical primary door types seen on historic residential structures.*



*If a door requires replacement keep the original door proportions.*

## Doors

### Policy:

The character-defining features of a historic door and its distinct materials and placement should be preserved. In addition, a new door should be in character with the historic building. This is especially important on primary facades.

### Guidelines:

9. **Preserve the decorative and functional features of a primary entrance.**
  - Maintain features important to the character of a historic doorway. These may include the door, door frame, screen door, threshold, glass panes, paneling, hardware, detailing, transoms and flanking sidelights.
  - Avoid changing the position and function of original front doors and primary entrances.
  
10. **Maintain the original proportions of a significant door.**
  - Altering its size and shape is inappropriate.
  
11. **When a historic door is damaged, repair it and maintain its general historic appearance.**
  
12. **When replacing a door, use materials that appear similar to that of the original.**
  - A metal door, if seen from the street, is inappropriate where the original was wood.
  
13. **When replacing a door, use a design that has an appearance similar to the original door, or a door associated with the style of the house or commercial building.**
  - Very ornate doors are discouraged, unless photographic evidence can support their use.
  
14. **If energy conservation and heat loss are a concern, consider using a storm door instead of replacing an historic entry door on a residential building.**
  - Generally, wood storm doors are most appropriate.
  - A metal storm door may be appropriate if it is simple in design and if the frame is painted so that raw metal is not visible.

## Roofs

### Policy:

The character of a historical roof should be preserved, including its form and materials, whenever feasible.

### Guidelines:

- 15. Preserve the original roof form of a historic structure.**
  - Avoid altering the angle of a historic roof. Instead, maintain the perceived line and orientation of the roof as seen from the street.
  - Retain and repair roof detailing.
- 16. Preserve the original eave depth of a historic structure.**
  - The shadows created by traditional overhangs contribute to one's perception of the building's historic scale and therefore, these overhangs should be preserved. Cutting back roof rafters and soffits or in other ways altering the traditional roof overhang is therefore inappropriate.
- 17. Minimize the visual impacts of skylights and other rooftop devices.**
  - The addition of features such as skylights or solar panels should not be installed in a manner such that they will interrupt the plane of the historic roof. They should be lower than the ridgeline.
  - Flat skylights that are flush with the roof plane may be considered on the rear and sides of the roof. Locating a skylight or a solar panel on a front roof plane should be avoided.
- 18. When planning a rooftop addition, preserve the overall appearance of the original roof.**
  - An addition should not interrupt the original cornice or ridgeline.
- 19. Preserve original roof materials.**
  - Avoid removing historic roofing material that is in good condition. When replacement is necessary, use materials that are similar to the original in both style as well as physical qualities and use a color that is similar to that seen historically.
  - Specialty materials such as tile, slate or concrete should be replaced with a matching material.
- 20. Avoid using conjectural materials or features on a roof.**
  - Adding a widow's walk (an ornate railing around the roof ridge) on a house where there is no evidence that one existed creates a false impression of the home's original appearance, and is inappropriate, for example.

### Typical Residential Roof Types

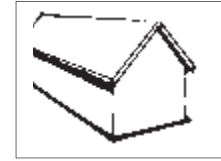

*Gabled roof*

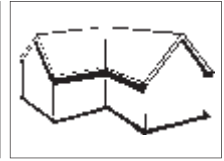

*Cross-Gabled roof*

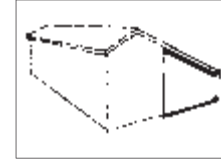

*Shed roof*

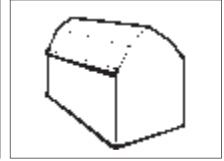

*Gambrel roof*



*Clipped Gable roof*

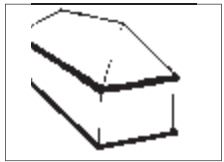

*Hipped roof*

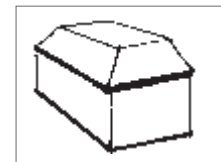

*Mansard roof*

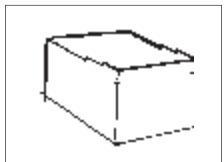

*Flat roof*



*Continuing the traditional roof line will preserve the integrity of the historic district.*



*Flat roofed buildings are commonly found in the downtown district.*

- 21. New or replacement roof materials should convey a scale and texture similar to those used traditionally.**
- Composite shingles work best for many types of buildings.
  - Roof materials should be generally earth tones and have a matte, non-reflective finish.
  - When choosing a roof replacement material the architectural style of the structure should be considered.
- 22. If they are to be used, metal roofs should be applied and detailed in a manner that is compatible with the historic character and does not distract from the historic appearance of the building.**
- Metal roof materials should be earth tones and have a matte, non-reflective finish.
  - Seams should be of a low profile.
  - The edges of the roofing material should be finished similar to those seen historically. The edges of standing seam metal roof were simply bent downward at the edges of the roof with a very slight overhang. In most cases the gutters hide this detail.
  - Note that metal roofs work best on homes with front-facing gable roofs, small homes and/or homes with simple roof forms.
  - Stamped metal panels should appear similar to those seen historically.
  - Many modern metal roofing materials do not have proportions that are appropriate to the historic character of many local neighborhoods.

## **Foundations**

### **Policy:**

There is one policy for the preservation of building foundations that serves as the basis for all related design guidelines and supporting information. The City will use this policy and associated design guidelines in making its decisions for a Certificate of Appropriateness. In cases where special conditions of a specific project are such that the detailed design guidelines do not appear to address the situation, this general policy statement will serve as the basis for determining the appropriateness of the proposed work. Keeping moisture away from a foundation is the primary objective.

### **Guidelines:**

- 23. Vines and other plants should not be allowed to grow on foundation walls.**
- Plants tend to retain moisture and keep damp walls from drying.
  - Weeds and shrubs should not be allowed to come in contact with foundation walls.
  - Avoid piling items such as firewood, trash, or mulch against a foundation wall, since these can hold moisture too and let it into the wall.

- 24. If the foundation walls have ventilation openings, be sure these are kept clear.**
- These help the walls dry out after getting wet (they also help keep moisture from building up in basements and crawl spaces).
  - Ventilation openings or basement windows should not be filled in with permanent materials such as brick or concrete block; try wood or metal panels in place of window glass if windows must be blocked up, but retain the wood or metal framing and sash.
- 25. Make sure the soil or pavement next to the foundation wall slopes away and not toward the wall.**
- Provide positive drainage away from foundations to minimize rising moisture.
  - This will keep water from soaking down into the wall and surrounding soil. Wet soil can lose its weight-supporting capacity and result in foundation and wall cracks.
  - Watch for open joints between pavement and foundation wall where water flowing down the wall can get into the soil.
- 26. Gutters and downspouts should not be clogged or leaking and should carry water away from the foundation wall.**
- During heavy rains, watch to see if water is flowing or dripping down the building wall and into the foundation.
  - Downspouts should be connected to underground drains if possible (check to be sure these are clear, too), or at least should empty onto splash blocks which carry the water away from the foundation wall.
- 27. Avoid cutting new window and door openings in foundation walls, or enlarging existing ones.**
- This can weaken the foundation significantly. If you need to make these alterations, get qualified advice on how the foundation will be affected.
- 28. Avoid covering foundations with inappropriate materials.**
- Materials such as composite “brick” wallpaper diminish the character of the structure.
  - These coverings can also hold moisture in the foundation wall and cause damage to the structure.



*This is an appropriate addition to the rear of a historic commercial building.*



*These images show buildings with alternative designs that are appropriate interpretations of a traditional storefront.*

## D. Rehabilitation of Historic Commercial Properties

### Preservation of Commercial Storefronts

#### Policy:

Many storefronts in Bozeman have components seen traditionally on commercial buildings. The repetition of these standard elements creates a visual unity at the street that should be preserved.

#### Guidelines:

1. **For a commercial storefront building, a rehabilitation project should preserve these character-defining elements:**
  - **Display windows:** The main portion of glass on the storefront, where goods and services are displayed.
  - **Transom:** The upper portion of the display window, separated by a frame.
  - **Kickplate:** Found beneath the display window. Sometimes called a bulk-head panel.
  - **Entry:** Usually set back from the sidewalk in a protected recess.
  - **Upper-story windows:** Windows located above the street level. These usually have a vertical orientation.
  - **Cornice molding:** A decorative band at the top of the building.
  - These features should not be altered, obscured or removed.
  - This will help maintain the interest of the street to pedestrians by providing views to goods and activities inside first floor windows.
  
2. **If a storefront is altered, restoring it to the original design is preferred.**
  - If evidence of the original design is missing, use a simplified interpretation of similar storefronts.
  - Historic photographs of Bozeman and its commercial buildings are widely available and should be used when determining the original character of a storefront design.
  
3. **Alternative designs that are contemporary interpretations of traditional storefronts may be considered where the historic facade is missing and no evidence of it exists.**
  - Where the original is missing and no evidence of its character exists, a new design that uses the traditional elements may be considered.
  - However, the new design should continue to convey the character of typical storefronts, including the transparent character of the display window.
  - Greater flexibility in treatment of rear facades is appropriate. However, care should be taken to preserve storefronts on those buildings which have traditional commercial storefronts on more than one facade, such as a corner building.

4. **Retain the kickplate as a decorative panel.**
  - The kickplate, located below the display window, adds interesting detail to the streetscape and should be preserved.
  - If the original kickplate is covered with another material, consider exposing the original design.
  
5. **If the original kickplate is missing, develop a sympathetic replacement design.**
  - Wood is an appropriate material for replacements on most styles. However, ceramic tile and masonry may also be considered when appropriately used with the building style.
  
6. **Preserve the character of the cornice line.**
  - Most historic commercial buildings have cornices to cap their facades. Their repetition along the street contributes to the visual continuity on the block.
  - Many cornices are made of sheet metal, which is fairly lightweight and easy to repair. Areas that have rusted through can be patched with pieces of new metal.



*Preserve the historic character of a storefront when it is intact.*



*Traditional Main Street building facade.*



*Typical commercial components.*

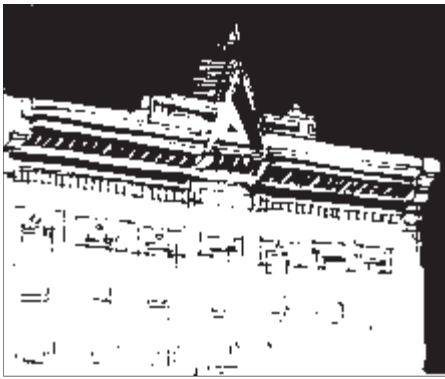

7. **Reconstruct a missing cornice when historic evidence is available.**
- Use historic photographs to determine design details of the original cornice.
  - Replacement elements should match the original in every detail, especially in overall size and profile. Keep sheet metal ornamentation well painted.
  - The substitution of another old cornice for the original may be considered, provided that the substitute is similar to the original.

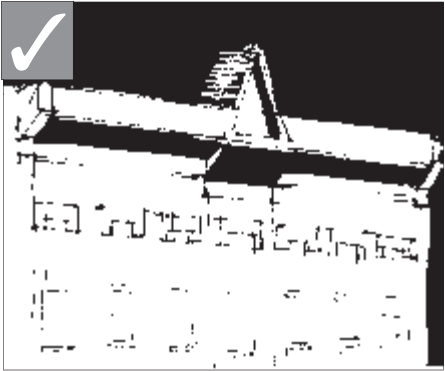

8. **A simplified interpretation is also appropriate for a replacement cornice if evidence of the original is missing.**
- Appropriate materials include stone, brick and stamped metal.

9. **Retain the original shape of the transom glass in historic storefronts.**

- Transoms, the upper glass band of traditional storefronts, introduced light into the depths of the building, saving on light costs. These bands should not be removed or enclosed.
- The shape of the transom is important to the proportion of the storefront, and it should be preserved in its historic configuration.
- If the original glass is missing, installing new glass is preferred. However, if the transom must be blocked out, be certain to retain the original proportions. One option might be to use it as a sign panel or decorative band.

*When the reconstruction of an element is impossible, a simplified interpretation is also appropriate.*

10. **A parapet wall should not be altered, especially those on primary elevations or highly visible facades.**

- When a parapet wall becomes deteriorated, there is sometimes a temptation to lower or remove it. Avoid doing this because the flashing for the roof is often tied into the parapet, and disturbing it can cause moisture problems.
- Inspect parapets on a regular basis. They are exposed to the weather more than other parts of the building, so watch for deterioration such as missing mortar or excessive moisture retention.
- Avoid waterproofing treatments, which can interfere with the parapet's natural ability to dry out quickly when it gets wet.

## Additions to Commercial Properties

### Policy:

Three distinct types of additions to historic commercial buildings may be considered. First, a ground-level addition that involves expanding the footprint of a structure may be considered. Such an addition should be to the rear or side of a building. This will have the least impact on the character of a building, but there may only be limited opportunities to do this.

Second, an addition to the roof may be designed that is simple in character and set back substantially from the front of a building. In addition, the materials, window sizes and alignment of trim elements on the addition should be compatible to those of the existing structure.

A third option, which only will be considered on a case-by-case basis, is to design an addition within the wall plane of the existing building. This option is the most difficult and requires the most care to respect the relationship of the building to the street. Such an addition should provide a visual distinction between the existing structure and its addition. This may be accomplished through the use of a belt course element or a subtle change in building materials.

### Guidelines:

11. **An addition should be compatible in scale, materials and character with the main building.**
  - An addition should relate to the building in mass, scale and form. It should be designed to remain subordinate to the main structure.
  - An addition with a pitched roof is inappropriate for a building with a flat roof.
  - An addition to the front of a building is inappropriate.
12. **An addition should not damage or obscure architecturally important features.**
  - For example, loss or alteration of a cornice line should be avoided.
13. **An addition may be made to the roof of a building if it does the following:**
  - An addition should be set back from the primary, character-defining facade, to preserve the perception of the historic scale of the building.
  - Its design should be modest in character, so it will not attract attention from the historic facade.
  - The addition should be distinguishable as new, albeit in a subtle way.

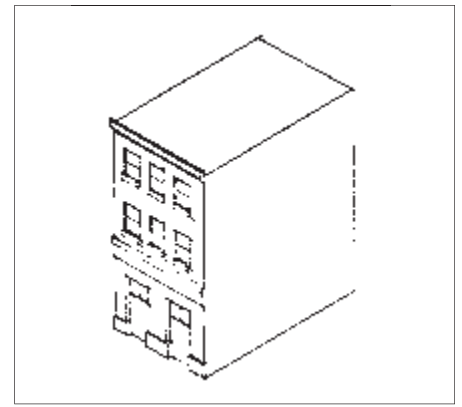

*An original three-story building, before an addition. Compare with sketches below.*

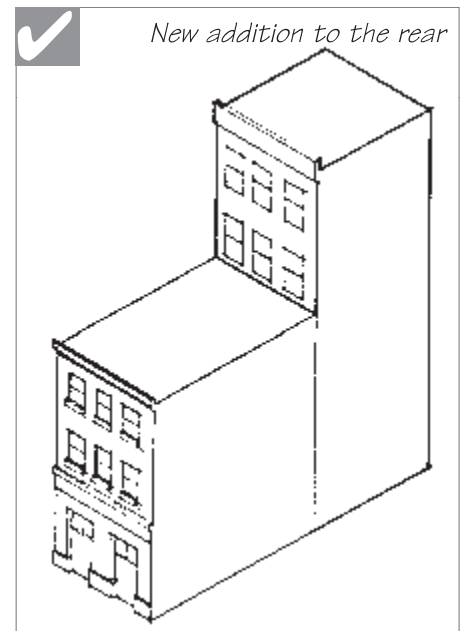
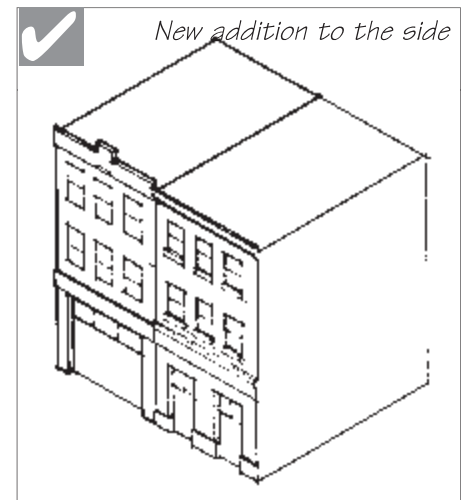

*Appropriate alternative approaches to additions.*



**14. In limited circumstances, an addition may be made to the roof of a building and not be set back from character-defining facades, if it does the following:**

- An addition should be distinguished from the existing building. A change in material or a decorative band can be considered to accomplish this.
- An addition should maintain the alignment of storefront elements, moldings, cornices and upper-story windows that exist on the main part of the building.
- The addition should also be compatible in scale, texture and materials with the original.

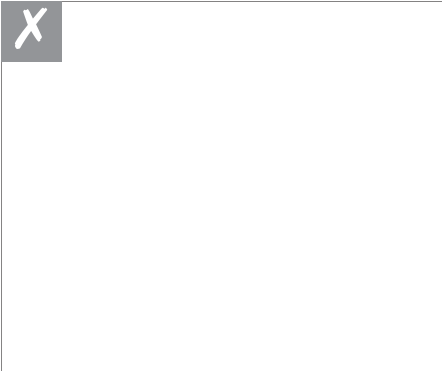

*Preserve an original porch. Avoid using a porch support that would be substantially smaller than other supports on the porch or than seen historically.*

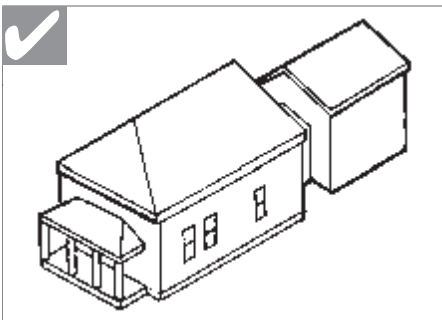

*Any new additions should not take away from the original historic structure. An addition on the back of a structure is acceptable.*

## Signs

### Policy:

Historically, signs that were mounted and/or painted on the exterior of a building advertised the primary business conducted there. Many of these signs still stand today and should be preserved when feasible.

### Guideline:

- 15. Preserve an historic sign where it exists, when feasible.**

## E. Rehabilitation of Historic Residential Properties

### Porches

### Policy:

#### *Preserve*

Preserve a porch in its original condition and form. A porch is one of the most important character-defining elements of a facade. Porches help to provide visual interest to a building, and can influence its perceived scale, protect entrances and pedestrians from rain and provide shade in summer.

### Guideline:

- 1. Maintain an original porch, when feasible.**
  - Maintain the existing location, shape, details and posts of the porch.
  - Missing or deteriorated decorative elements should be replaced to match existing elements; e.g., match the original proportions and spacing of balusters when replacing missing ones.
  - Avoid using a porch support that would be substantially smaller than other supports on the porch or than that seen historically.
  - Do not remove an original porch from a building.
- 2. Enclosing a porch with opaque materials that destroy the openness and transparency of the porch is inappropriate.**
  - Where a porch must be enclosed, use transparent materials (such as glass) and place them behind the balusters and balustrade to preserve the visual character of the porch.

**3. Where building codes stipulate that new porch railings lower than 36 inches in height be augmented or corrected to raise their effective height to 36 inches, consider the following:**

- Provide a smaller railing above the historic railing to achieve a greater overall railing height.

**Policy:**

**Repair**

Repair a deteriorated porch instead of removing or replacing it. The preferred treatment for an altered porch is to repair it, rather than replace it altogether. This approach is preferred because the original materials contribute to its historic character. Even when replaced with an exact duplicate, a portion of the historic building fabric is lost; therefore, such treatment should be avoided when feasible.

**Guidelines:**

**4. Repair those elements of a porch that are deteriorated.**

- Removing damaged materials that can be repaired is not appropriate.

**5. Consider restoring an altered porch back to its original design and configuration.**

- If the historic design of the porch is unknown, then base the design of the restoration on other traditional porches on buildings of a similar architectural style.
- If the original porch steps have been replaced with concrete, consider restoring them to their original, wood condition. If termite control is of concern, then consider only making the bottom step concrete and not the entire stair assembly.

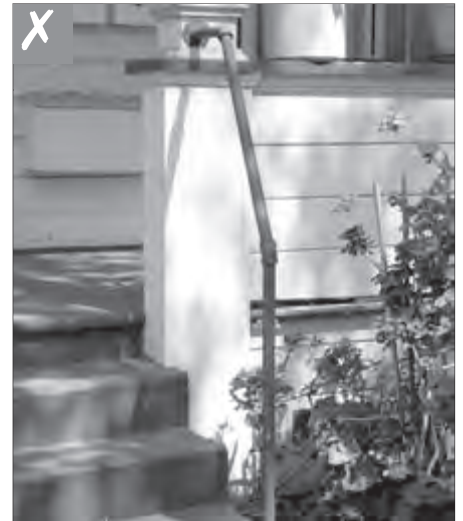

*While a simple design solution, the use of metal pipes as replacement porch rails is inappropriate.*



*The porch on the left has experienced an inappropriate alteration; enclosed railing. Compare it with its “rehab” in the photo to the right.*

**Policy:**

**Replace**

Replace a missing porch with one that appears similar to that seen historically. When a porch is to be replaced, the first step is to research the history of the house to determine the appearance and materials of the original porch. The most important aspects of a replacement design are its location, scale and materials. Unless reconstructing a porch from historical documentation, it is not necessary to replicate the details of the original porch or a porch design copied from a similar style house. However, it is important that new details be compatible (similar form, scale and materials) for the design of the porch and the style of the house.

**Guidelines:**

**6. When porch replacement is necessary, it should be similar in character, design, scale and materials to those seen traditionally.**

- The size of a porch should relate to the overall scale of the primary structure to which it is attached.
- Base the design of a replacement porch on historical documentation if available.
- Where no evidence of the historic porch exists, a new porch may be considered that is similar in character to those found on comparable buildings.



*Existing Condition: Craftsman style house with an enclosed porch.*



*Preferred Approach, when historical documentation is available: Craftsman style house with a replacement porch designed similar to that seen historically.*



*Acceptable Approach, when historical documentation is not available: Craftsman style house with a simplified interpretation of a traditional porch design.*



*Existing Condition: A folk or vernacular style house with the original porch removed.*



*Preferred Approach, when historical documentation is available: A folk or vernacular style house with a replacement porch designed similar to that seen historically.*



*Acceptable Approach, when historical documentation is not available: A folk or vernacular style house with a simplified interpretation of a traditional porch design.*

**7. Porch supports should be of an appropriate size to compliment the entry and existing structure.**

- Wood columns are best for most structures in Bozeman.
- Brick or stone may be appropriate for some architectural styles.
- See the style section of the guidelines for further recommendations.

**8. A porch should use similar materials to that seen historically.**

- Use materials similar to those seen historically. Wood decking, steps, balustrades and porch supports were most common.
- While matching original materials is preferred, when detailed correctly and painted appropriately, fiberglass columns may be considered.
- Do not replace a wood porch decking and steps with concrete.

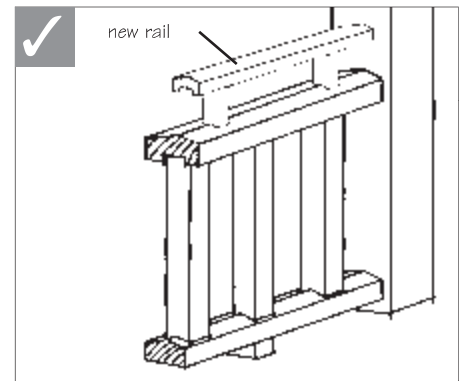

*Consider providing a smaller railing above the historic railing to achieve a greater overall railing height.*

## Additions to Residential Properties

### Policy:

When planning an addition to an existing building, consider the effect it will have on the structure. The following guidelines avoid any negative impacts of an addition: While the choice of a style is not a concern of these principles, there is an awareness that each property has some style that helps define its character. Additions that reflect elements of the existing predominant style reinforce the positive character. Those elements that seem unintentionally foreign to the individual property and detract from the overall design should be minimized and not considered positive elements to base the design of an addition on.

### Guidelines:

**9. The loss of historically significant features, where they exist, should be minimized.**

- When preserving original details and materials, follow the guidelines at the beginning of this chapter.

**10. Place an addition at the rear of a building or set it back from the front to minimize the visual impacts.**

- This will allow the original proportions and character to remain prominent.
- A roof top addition should be set back at least 10 feet from a primary facade.



*This detail shows ornate rafters which should be preserved during a rehabilitation process.*



*These additional structures are set back from the facade of the original historic home.*

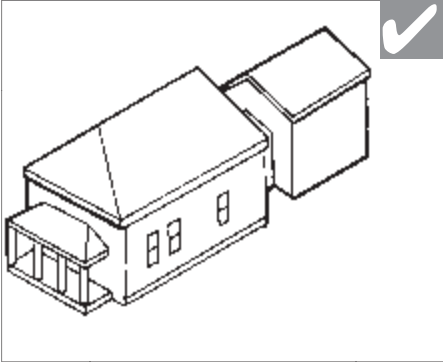

*This addition is set back behind the original structure and the new addition is accessed by a connector.*

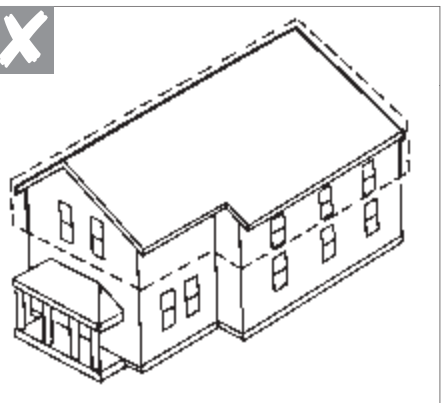

*This roof top addition is not subordinate to the existing structure.*

11. **A new addition should respect the mass and scale of the original structure.**
  - While a smaller addition is visually preferable, if the addition would be significantly larger than the original building, one option is to separate it from the primary building, when feasible, and then link it with a smaller connector.
  - In some cases, adding vertically, through construction of dormers, will help to minimize the impacts of additions and preserve rear yards.
  - A new addition should fit within the range of stories that help define the character of the neighborhood.
  - For a larger addition, break up the mass of the addition into smaller modules that relate to the historic house.
  - An addition should be simple in design to prevent it from competing with the primary facade.
  
12. **The roof form of a new addition should be in character with and subordinate to that of the primary building.**
  - It is important to repeat the roof lines and slopes found on the primary structure. Typically, gable, hip and shed roofs are appropriate for residential-type building additions. Flat roofs may be appropriate for commercial buildings or International style structures.
  
13. **When constructing a rooftop addition, keep the mass and scale subordinate to the primary building.**
  - The addition should not overhang the lower floors of the primary building.
  
14. **When adding a dormer, it should be in character with the primary structure's design.**
  - A dormer should be subordinate to the overall roof mass and should be in scale with ones on similar historic structures.
  - The dormer should be located below the ridge line of the primary structure.
  - The number and size of dormers should not visually overwhelm the scale of the primary structure.
  - Dormers are typically added to a structure to increase the amount of headroom in upper floors. Traditionally, dormers are designed as smaller elements. If significant increases in space are desired, do not consider oversized dormers. Rather, develop an addition to the rear of a structure.
  
15. **Raising a building may be considered only if significant features are preserved.**
  - The historic porch design must remain intact.
  - Minor alterations to porch stairs may be considered, but the overall design must be preserved.
  - Window and door locations and alignments should remain intact.

## F. Secondary Structures

### Policy:

Preserving the historic fabric along an alley in a historic district is important. This includes sheds, garages and carriage houses. They are traditionally subordinate in scale and character to the primary structure and are typically located to the rear of the lot. These features should be retained.

### Guideline:

1. **Preserve an existing secondary structure when feasible.**
  - Retain original materials when feasible.
  - Maintain the subordinate character of the structure also.

## G. Adaptive Re-Use

### Policy:

Converting a building to a new use that is different from that which its design reflects is considered to be “adaptive re-use.” For example, converting a residential building to an office is adaptive re-use. A good adaptive re-use project retains the historic character of the building while accommodating its new function.

### Guideline:

1. **Seek uses that are compatible with the historic character of the building.**
  - Building uses that are closely related to the original use are preferred. An example would be the conversion of a residential-type building to an office. This can be accomplished without radical alterations to either the interior or exterior of the structure.
  - Avoid altering porches and original windows and doors.

## H. Historic Additions

### Policy:

Some early additions may have taken on historic significance of their own. One constructed in a manner that was compatible with the original building and that is associated with the period of significance may merit preservation in its own right, these additions should be evaluated.

In contrast, more recent additions that detract from the character of the building should be considered for removal.

### Guideline:

1. **Preserve an older addition that has achieved historic significance in its own right.**
  - For example, a porch or a kitchen wing may have been added to the original building early in its history. Such an addition is usually similar in character to the original building in terms of materials, finishes and design.



*This building has been successfully adapted from a single-household home to a bed and breakfast in the Bozeman Brewery Historic District.*



# CHAPTER 2

# DESIGN GUIDELINES

# FOR ALL PROPERTIES



*Appropriate new infill building for the commercial character area.*

## **In this Chapter:**

- A. Topography
- B. Street Patterns
- C. Alleys
- D. Streetscape
- E. Landscape Design
- F. Building Form
- G. Solid-to-Void Ratio
- H. Materials
- I. Architectural Character
- J. Parking
- K. Buffers
- L. Site Lighting
- M. Utilities and Services

This chapter covers design guidelines for all properties. It includes a variety of topics that may arise in rehabilitation projects, new building designs and site improvements.

# CHAPTER 2

## DESIGN GUIDELINES

### FOR ALL PROPERTIES

#### A. Topography

##### Policy:

Site work should be planned to protect the assets of the existing topography.

##### Guidelines:

- 1. Minimize cut and fill on a site.**
  - Divide large grade changes into a series of benches and terraces, where feasible.
- 2. Design a building foundation to conform to the existing topography, rather than creating extensive cut and fill.**
  - Step the foundation of a building to follow site contours, when feasible.
  - If stepping the foundation is not possible, disguise the cut with building placement and/or building walls, and provide a landscape buffer system at the top of cut.
- 3. Minimize the visual impacts of cut and fill on a site.**
  - Regrade the site as a stable, “natural” slope, when feasible.

#### B. Street Patterns

##### Policy:

Historic settlement patterns seen in street and alley plans often contribute to the distinct character of the historic district and therefore they should be preserved. These street plans influence the manner in which primary structures are sited and they also shape the manner in which secondary structures and landscape features may occur on the site.

##### Guidelines:

- 1. Respect historic settlement patterns.**
  - Site a new building such that it is arranged on its site in a way similar to historic buildings in the area. This includes consideration of building setbacks and open space.

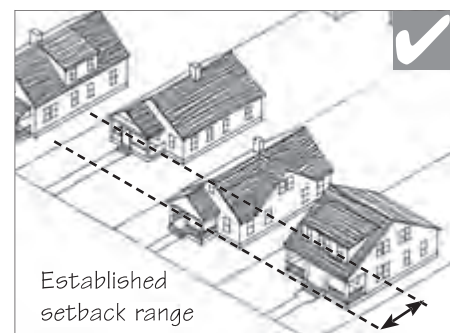

*Where there is uniform alignment, a new building should match the existing buildings on a block. In other cases, where there is a narrow range of variation in setback, then new building may fit within that established range.*



*Maintain the traditional character of the streetscape. The character changes between commercial and residential areas. In commercial areas street trees, light fixtures and furnishings accent the public sidewalk. In residential areas planting strips are typically found between the curb and sidewalk.*

## C. Alleys

### Policy:

Alleys accommodate service functions and provide pedestrian connections and secondary vehicle access. All alleys, both paved and unpaved, contribute to the character of the district.

### Guidelines:

- 1. Unpaved lanes contribute to the distinct character of the neighborhood; therefore, they should continue in their "rustic" state, when feasible.**
  - In some instances where it is necessary to keep dust levels down, and it is necessary to pave the alley, recycled asphalt is the preferred material.
- 2. The traditional scale and width of alleys should be continued.**
  - Maintain the traditional character and scale of an alley by locating buildings and fences along the alley edges to maintain the alley edge.

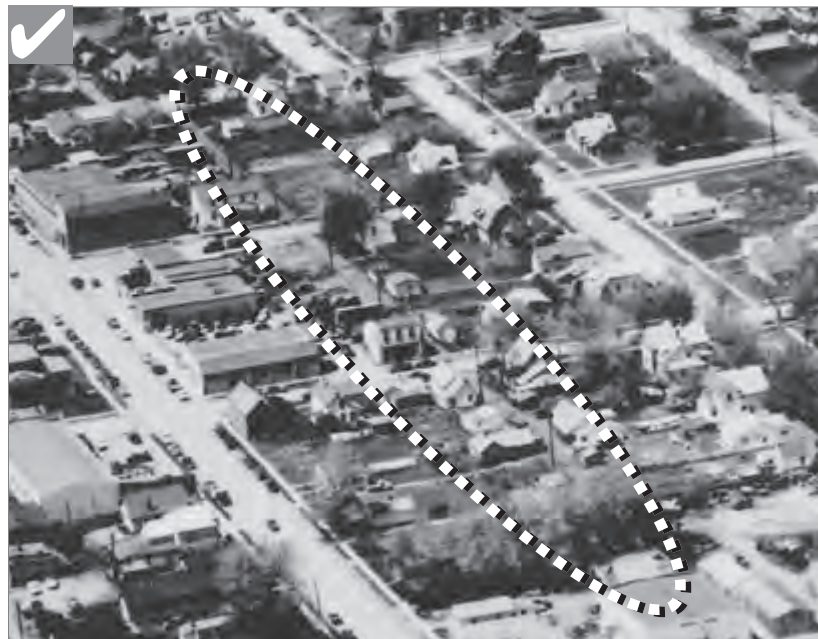

*The traditional scale and width of alleys can be viewed in this 1940 photograph. Note the secondary structures that line the alley edge, much like they do today. (Photo credit: Gallatin County Historical Society)*

## D. Streetscape

### Policy:

Maintain the traditional character of the streetscape. This includes a rich collection of varying street designs, sidewalk types and street trees.

### Guidelines:

1. **Maintain the variety of street paving designs.**
  - Most streets in the neighborhood are paved and have both curb and gutter. However, some streets lack sidewalks or paving. Thus, they possess their own character and serve as informal pedestrian ways. This tradition of unpaved streets should continue when it is not a hazard to pedestrians or bicyclists.
2. **Maintain the variety of sidewalk designs.**
  - Where a detached (sidewalks separated from the street by a strip of grass) sidewalk exists, it should be preserved.
  - Where no sidewalk exists a new sidewalk is required; it should be constructed to be in character with the traditional sidewalks in the neighborhood.
3. **Continue the use of planting strips.**
  - Planting strips should act as a transition between public and semi-public spaces.
  - Where planting strips between the curb and sidewalk exist they should be maintained.
  - If new detached sidewalks are installed in the neighborhood, new planting strips should be provided.
4. **Continue the pattern of street trees in a block. Because street trees serve various aesthetic and practical functions, they should be maintained.**
  - Existing street trees should be preserved, when feasible.
  - If a new detached sidewalk is to be created, street trees should be an accompanying feature.
  - If a new sidewalk is to be installed, it should detour around mature street trees, when feasible.
  - When an existing street tree dies, it should be replaced.
  - Any new developments should include street trees.
  - The historic urban design character for street tree placement should be considered when enforcing city street standards.



*Bozeman should preserve the mature trees that line the street.*

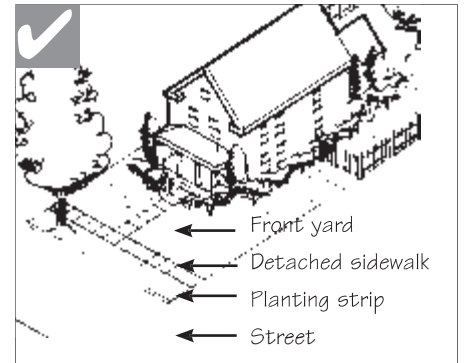

*Streetscapes such as these should be continued throughout the neighborhoods. Notice the lack of fences in the front yards and the use of sidewalks and planting strips.*

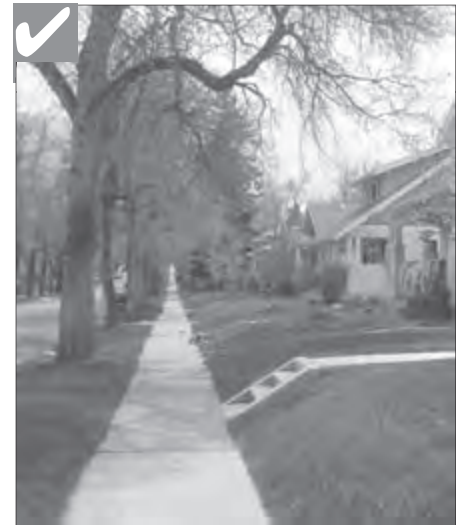

*Continue the pattern of street trees in residential neighborhoods.*



Notice the traditional gabled roof used as well as the porch; these make up the overall building form.

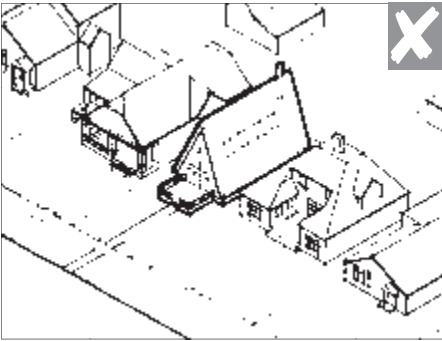

Avoid using exotic roof forms such as this A-frame example. Notice the discontinuity in building forms along the street.

## E. Landscape Design

### Policy:

Traditionally, plant beds were located around building foundations, along walkways and sometimes in front of fences. Some of these plantings may have historic significance and should be retained, to the extent feasible. Some mature trees may also contribute to the historic landscape and should be preserved.

### Guidelines:

- 1. Preserve and maintain mature trees and significant vegetation within all corridors.**
  - Include existing vegetation as a part of a landscape design scheme where appropriate.
  - In development areas, healthy trees and vegetation clusters should be identified for preservation. Special consideration should be given to mature trees, 6" or greater in diameter, and to vegetation clusters with significant visual impact. Vegetation designated for preservation should be incorporated into new development site design to the maximum extent possible.

## F. Building Form

### Policy:

A similarity of building forms also contributes to a sense of visual continuity. In order to maintain this sense of visual continuity, a new building should have basic roof and building forms that are similar to those seen traditionally. Overall facade proportions also should be in harmony with the context.

### Guidelines:

- 1. Use building forms that are similar to those seen traditionally on the block.**
  - Simple rectangular solids are typically appropriate.
- 2. Exotic building and roof forms that would detract from the visual continuity of the street are discouraged.**
  - Geodesic domes and A-frames are not generally considered traditional building forms and should not be used in the designated historic districts.
  - Sloping roof forms such as gable and hip roofs are appropriate in most residential and transition areas.
  - Flat roofs are appropriate in most commercial and transition areas, and in some cases may be appropriate in residential areas.

## G. Solid-to-Void Ratio

### Policy:

A typical building appeared to be a rectangular solid, with small holes “punched” in the walls for windows and doors. Most buildings had similar amounts of glass, resulting in a relatively uniform solid-to-void ratio. This ratio on a new building, the amount of facade that is devoted to wall surface, as compared to that developed as openings, should be similar to that of historic buildings within the neighborhood.

### Guideline:

1. **Use a ratio of solid-to-void (wall-to-window) that is similar to that found on historic structures in the district.**
  - Large surfaces of glass may be inappropriate. Divide large glass surfaces into smaller panes similar to those seen traditionally.

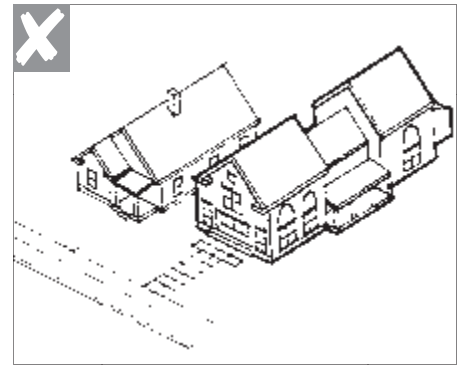

*Using too much glass in areas visible from the street is out of character in a residential neighborhood.*



*This new infill commercial building uses a traditional solid-to-void (wall-to-window) ratio that is found on commercial structures in the downtown district, which is appropriate.*



*Use building materials that appear similar to those used traditionally in the area.*



*The use of hardiplank horizontal lap siding is appropriate in most residential neighborhoods outside of the historic district.*

## H. Materials

### Policy:

Building materials of new structures and additions to existing structures should contribute to the visual continuity of the neighborhood. They should appear similar to those seen traditionally to establish a sense of visual continuity.

### Guidelines:

- 1. Use building materials that appear similar to those used traditionally in the area.**
  - Horizontal lap siding is appropriate in most residential neighborhoods. Brick and stone are also appropriate in most areas.
  - All wood siding should have a weather-protective finish.
  - The use of highly reflective materials is discouraged.
- 2. The use of masonry that appears similar in character to that seen historically is appropriate.**
  - Brick should have a modular dimension similar to that used traditionally. Brick larger than the nominal 2-3/8" x 8" is discouraged.
  - Stone, similar to that used traditionally, is also appropriate.
- 3. New materials that are similar in character to traditional materials may be acceptable with appropriate detailing.**
  - Alternative materials should appear similar in scale, proportion, texture and finish to those used traditionally.
- 4. Use building materials that contribute to the traditional sense of scale of the block.**
  - This will reinforce the sense of visual continuity in the district.



*The use of masonry that appears similar in character to that seen historically is appropriate.*

# I. Architectural Character

## Policy:

New construction should distinguish itself from historic structures.

## Guidelines:

**1. The imitation of older historic styles is discouraged for newer structures.**

- One should not replicate historic styles, because this blurs the distinction between old and new buildings, as well as making it more difficult to visually interpret the architectural evolution of the district.

**2. Contemporary interpretations of traditional details are encouraged.**

- Interpretations of historic styles may be considered, if they are subtly distinguishable as being new.
- New designs for window moldings and door surrounds, for example, can provide visual interest while helping to convey the fact that the building is new. Contemporary details for porch railings and columns are other examples. New soffit details and dormer designs also could be used to create interest while expressing a new, compatible style.



*Contemporary interpretations of traditional details are encouraged.*



Where a parking lot abuts a public sidewalk, provide a visual buffer.

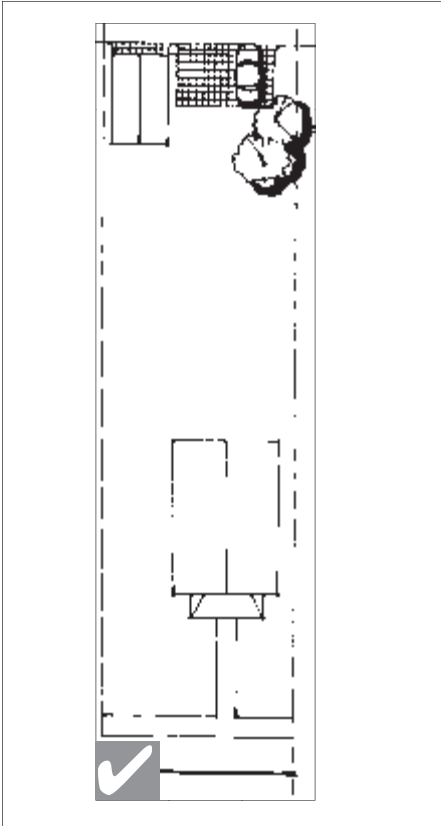

In residential neighborhoods where alley access is possible the use of parking off the alley is preferred and appropriate. Marking the parking spaces with a different type of material is appropriate as well.

## J. Parking

### Policy:

The visual impact of surface parking should be minimized. On site parking should be subordinate to other uses and the front of the lot should not appear to be a parking area.

### Guidelines:

1. **Minimize the visual impact of surface parking in residential neighborhoods.**
  - A parking area should be located to the rear of a site.
  - Do not use a front yard for parking. Instead, use a long driveway, or alley access, that leads to parking located behind a building.
  - Consider using ribbon paving in residential neighborhoods to minimize the amount of hard surface paving.
2. **Locate a surface lot in the interior of a block whenever possible.**
  - This acknowledges the special function of corner properties, as they are generally more visible than interior lots, serve as landmarks and provide a sense of enclosure to an intersection.
3. **Site a surface lot so it will minimize gaps in the continuous building wall of a commercial block.**
  - Where a parking lot shares a site with a building, place the parking at the rear of the site or beside the building.

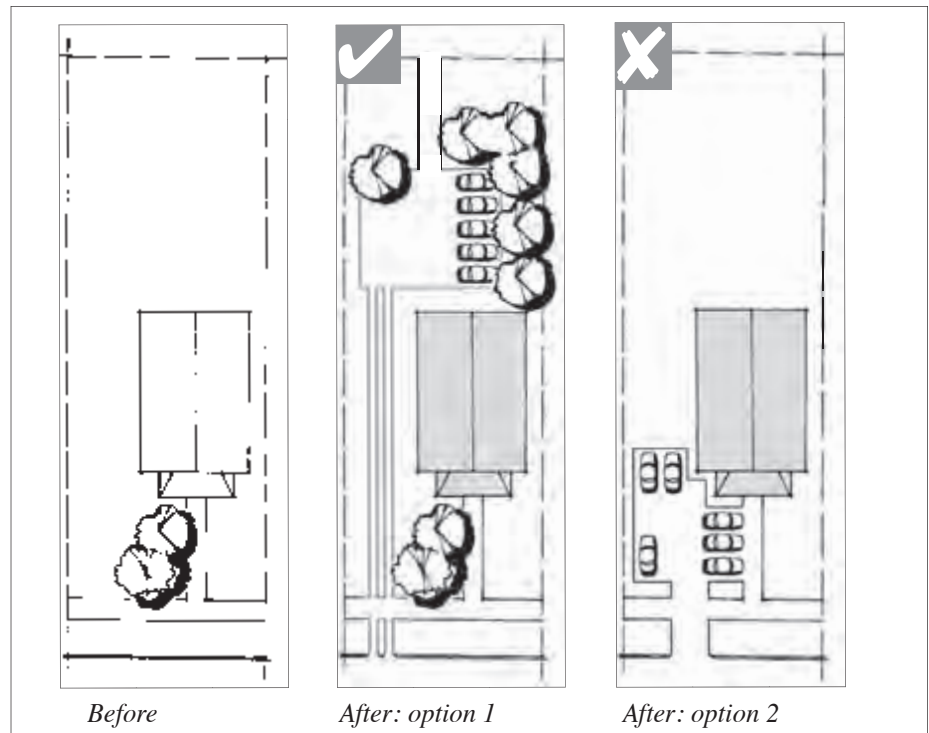

In commercial or adaptive re-use areas parking is preferred to be set to the rear of the structure.

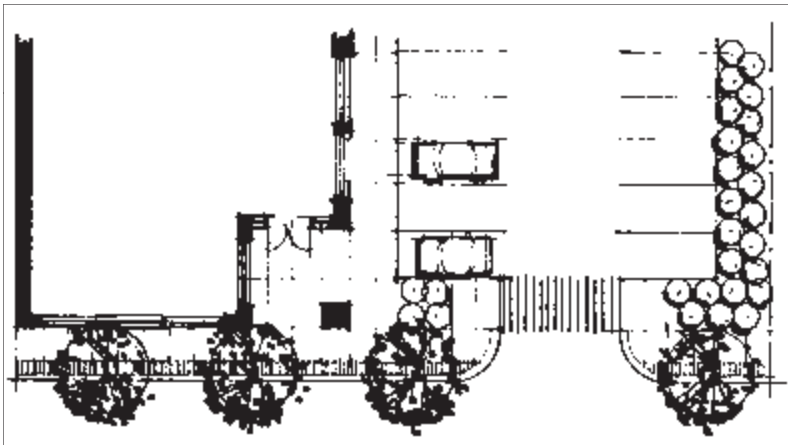

*Where a parking lot abuts a public sidewalk, provide a visual buffer.*

4. **Where a parking lot abuts a public sidewalk, provide a visual buffer.**
  - This may be a landscaped strip or planter. A combination of trees and shrubs can be used to create a landscape buffer.
  - Consider the use of a wall as screen for the edge of the lot. Materials should be compatible with those of nearby buildings.

## **K. Buffers**

### **Policy:**

When site development such as parking, storage and equipment areas create an unavoidable negative visual impact on abutting properties or to the public way, it should be mitigated with landscaping that may buffer or screen it. The landscape design should complement the existing natural character and context of the site.

Note that these guidelines supplement the city standards in Title 18, BMC, that define the minimum amounts of land area to be landscaped and of plant units to be used.

### **Guidelines:**

1. **Landscape buffers should be provided along edges of parking and service areas.**
  - Provide a landscape buffer at the edge of a parking lot and between parking lots.
  - In some cases it may be desirable to provide a landscape buffer between a recreation trail and/or open space. These should complement the natural character of the site.
  - Finally, it may be desirable to provide an evergreen landscape buffer at ground mounted mechanical equipment, service and/or storage areas.



*Minimal shed structures, such as this may be utilized at the alley edge.*

## L. Site Lighting

### Policy:

Standards for outdoor lighting are provided in the Unified Development Ordinance. This section addresses some of the qualitative aspects of lighting design that should also be addressed.

Light spill onto adjacent properties and into the night sky should be minimized. The light level at the property line is a key design consideration. This is affected by the number of fixtures, their mounting height, and the lumens emitted per fixture. It is also affected by the screening and design of the fixture.

### Guidelines:

- Lighting shall be shielded to prevent any off-site glare.**
  - Light fixtures should incorporate cut-off shields to direct light downward.
  - Luminaires (lamps) shall not be visible from adjacent streets or properties.



*Service areas should be visually unobtrusive and should be integrated with the design of the site and the building.*

## M. Utilities and Service Areas

### Policy:

Service areas should be visually unobtrusive and should be integrated with the design of the site and the building.

### Guidelines:

- Orient service entrances, waste disposal areas and other similar uses toward service lanes and away from major streets.**
  - Screen service entrances with walls, fences or plantings.
  - When it will be visible from a public way, a service area screen should be in character with the building and site it serves.
  - Locate areas for outdoor storage, truck parking, trash collection or compaction loading, or other such uses so as not to be visible from abutting streets.
- Position service areas to minimize conflicts with other abutting uses.**
  - Minimize noise impacts by locating sources of offensive sounds away from other uses.
  - Use an alley system to locate service areas, when feasible.

## CHAPTER 3

# GUIDELINES FOR RESIDENTIAL CHARACTER AREAS



*While the porch serves as a transition area from the street to the house, it is also an essential element of the streetscape: It provides human scale to the house; it offers interest to pedestrians; and it is a catalyst for personal interaction.*

## **In this Chapter:**

- A. Hierarchy of Public and Private Space
- B. Building Mass and Scale
- C. Roof Form
- D. Secondary Structures
- E. Multi-Household
- F. Fences and Retaining Walls

This chapter discusses the guidelines for residential character areas. It applies to new infill projects in the residential neighborhoods in both the Neighborhood Conservation Overlay District and individual Historic Districts.

# CHAPTER 3.

## GUIDELINES FOR RESIDENTIAL CHARACTER AREAS

### A. Hierarchy of Public and Private Space

#### Policy:

The hierarchy of public and private space is a progression that begins at the street, which is the most public space, proceeds through the front yard, which appears "semi-private," and ends at the front door, which is the "private" space. This sequence enhances the pedestrian environment and contributes to the character of the neighborhood; it should be maintained.

#### Guidelines:

- 1. Provide a front yard similar in character to its neighbors when possible.**
  - The front yard should be maintained in a traditional manner, with planting material, and not covered with paving or large outdoor decks.
- 2. Provide a walkway from the street to the building.**
  - A walkway running from the street to the front porch provides unity to the streetscape. Where a walkway has been an element of the hierarchy, this should continue.
- 3. Orient the front porch to the street.**
  - While the porch serves as a transition area from the street to the house, it is also an essential element of the streetscape: It provides human scale to the house; it offers interest to pedestrians; and it is a catalyst for personal interaction.
  - This should not be interpreted to exclude side porches.
- 4. Clearly define the primary entrance by using a front porch.**
  - The porch should be "functional," in that it is used as a means of access to the entry.



*The overall set back must be consistent to provide a uniform streetscape.*



*Provide a walkway from the street to the building.*



*Clearly define a primary entrance with a front porch.*



The drawing on the left shows a structure which does not relate well in mass and scale to the adjacent structure.

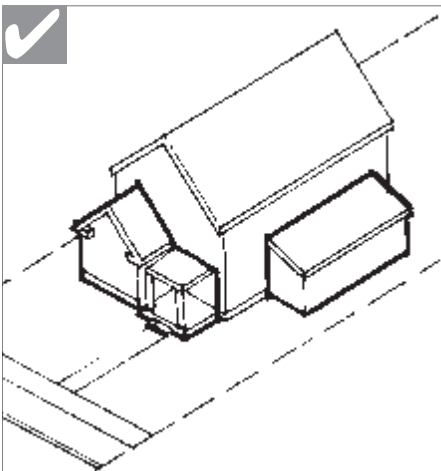

In order to minimize the perceived scale of a building, step down its height toward the street, neighboring structures and the rear of the lot.



On larger structures, subdivide larger masses into smaller “modules” that are similar in size to single household residences seen historically.

## B. Building Mass and Scale

### Policy:

The mass and scale of a building is also an important design issue in a residential character area. The traditional scale of single household houses dominates the neighborhood, and this similarity of scale also enhances the pedestrian-friendly character of many streets. Similarities in scale among prominent building features, such as porches and fences, are also important. In many cases, earlier buildings were smaller than current tastes support; nonetheless, a new building should, to the greatest extent possible, maintain this established scale. While new buildings and additions are anticipated that may be larger than many of the earlier structures, this new construction should not be so dramatically greater in scale than the established context that the visual continuity of the neighborhood would be compromised.

### Guidelines:

1. **Construct a new building to be similar in mass and scale to those single household residences seen traditionally.**
  - Traditional features that convey a human scale should also be used. Consider these techniques:
    - Use building materials that are of traditional dimensions.
    - Provide a one-story porch that is similar to those seen traditionally.
2. **On larger structures, step down a building's height toward the street, neighboring structures and the rear of the lot.**
  - When zoning regulations permit, the back side of a building may be taller than the established norm if the change in scale will not be perceived from public ways.
3. **On larger structures, subdivide larger masses into smaller “modules” that are similar in size to single household residences seen traditionally.**
  - Other, subordinate modules may be attached to the primary building form.
4. **The front wall of a new structure should not exceed two stories in height.**
  - The primary plane of the front should not appear taller than those of typical historic structures in the block.
  - A new multi-household structure should not overwhelm existing single household structures, in terms of height.
5. **A facade should appear similar in dimension to those seen traditionally in the neighborhood.**
  - Typically, a residential building front ranges from 14-30 feet in width. Additional widths were accomplished with a setback or change in building plane.

## C. Roof Form

### Policy:

In most neighborhoods, a similarity of roof form also contributes to a sense of visual continuity. In order to maintain this sense of visual continuity, a new building should have basic roof form that is similar to those seen traditionally.

### Guideline:

1. **Use roof forms that are similar to those seen traditionally on the block.**
  - The primary ridge line of a residential structure should not exceed the typical maximum for the block.

## D. Secondary Structures

### Policy:

Secondary structures are traditionally subordinate in scale and character to the primary structure and are typically located to the rear of the lot, they are primarily used for parking garages and storage. While structures in the rear generally have little impact on the character of the street they do have an impact on the character of the alley and the neighbors to the rear, this character should be maintained.

### Guidelines:

1. **A new secondary structure should be subordinate in height to those buildings seen traditionally along the street front.**
  - Secondary structures that are no more than one or one-and-one-half stories in height are preferred.
2. **Locate secondary buildings to the rear of the lot.**
  - Locating a secondary structure to the side of the primary structure, but set back significantly from the front wall plane is also appropriate
  - A secondary structure should be oriented similar to those seen traditionally along the alley, where they are available.
3. **Locate a garage such that its visual impacts will be minimized is encouraged.**
  - If a garage must be accessed from the street, set it back from the front wall plane when feasible.
  - When a garage must be located on the front wall plane, the percentage of building front allocated to it should be minimized.



*A facade should appear similar in dimension to those seen traditionally in the neighborhood.*

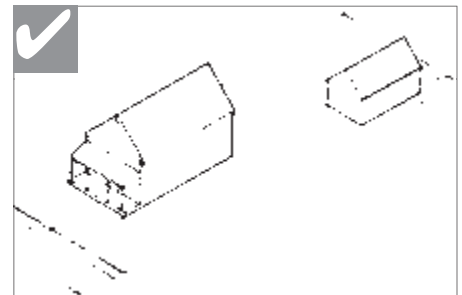

*Locate secondary buildings to the rear of the lot.*

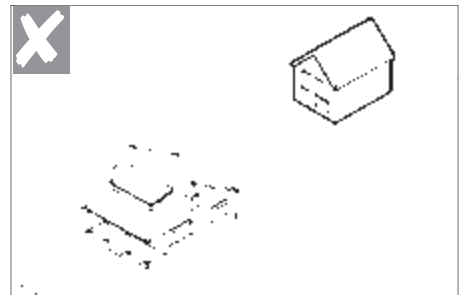

*This secondary structure is not subordinate to the original structure because the new structure is of equal height.*

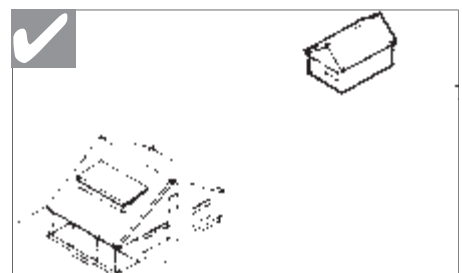

*This secondary structure is only one story and therefore is subordinate to the original structure.*

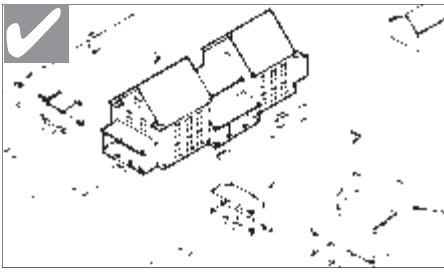

## E. Multi-household

### Policy:

The underlying goal of the guidelines in this section in regards to multi-household construction is that, to the greatest extent feasible, the buildings should be compatible with the context of the neighborhood. Historic structures associated with the multi-household projects should be retained when feasible.



*The proportions of window and door openings should be similar to those used traditionally in the neighborhood.*

The guidelines in other sections of this chapter also apply to multi-household buildings.

### Guidelines:

- 1. Retaining an existing single household building that contributes to the established character of the neighborhood in a multi-household project is encouraged.**
  - This will help maintain the traditional scale and character of single household houses as seen from the street.
  - In particular, an existing structure that is listed as a historic property should be preserved, when feasible.
  - When proposing a new design for a multi-household structure that must replace an existing building, however, also continue the rhythm that is established by the even spacing of building fronts along the street
- 2. Minimize the perceive scale of a multi-household building.**
  - In order to minimize the perceived scale of a building, one method is to step down its height toward the street, neighboring structures and the rear of the lot.
  - In order to break up the perceived mass of a structure, one method is to divide it into "modules" that are similar in size to buildings seen traditionally in the neighborhood.
- 3. Use traditional features that will convey a human scale.**
  - The ratio of wall-to-window, as seen from the public way, should appear similar to that of traditional single household structures.
  - Provide a one-story porch, or similar element, which will define a front door or entrance and be oriented to the street.
- 4. A new multi-household building should be within the range of heights seen traditionally in the neighborhood.**
  - A new multi-household structure should not overwhelm existing single household structures, in terms of height.
  - Maintaining a consistency of building height will contribute to the visual continuity of the streetscape.
  - The back side of a building may be taller than the front, and still appear to be in scale, if zoning regulations permit and the change in scale will not be perceived from public ways.

**5. A primary building face should not exceed the width of a typical single household building in a similar context (see illustrations).**

- Divide a large facade into subordinate wall planes that have dimensions similar to those of single household buildings, when feasible.
- Develop a large lot with several buildings, rather than one large single structure, when feasible.
- When a building is perpendicular to the street, on a lot perpendicular to the street, the typical range of front facade widths is 20 to 40 feet.
- When a building is parallel to the street, on a lot perpendicular to the street, the typical range of front facade widths is 30 to 40 feet.
- When a building is parallel to the street, on a lot parallel to the street, the typical range of front facade widths is 40 to 75 feet. Note that this is more typical of corner lots.

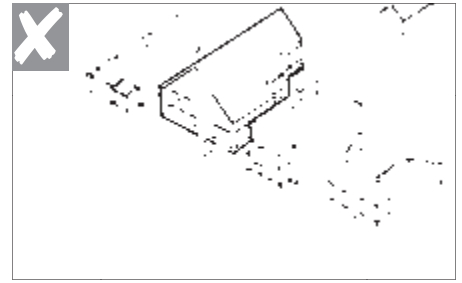

*This new multi-household household building is not consistent with the traditional width of the surrounding*

**6. The proportions of window and door openings should be similar to those used traditionally in the neighborhood.**

- This will help maintain the established ratio of wall-to-window and reinforce the traditional scale of the building.
- Large expanses of glass are discouraged.
- Divide large glass surfaces into smaller windows to reduce their perceived scale.



*The new multi-household building is similar in width to the traditional buildings. This also illustrates the use of dormers to better break up the space.*

**7. Brick, stone and painted wood are preferred primary building materials.**

- A much wider range of secondary and trim materials (including wood, metal, glass and synthetics) occurs.

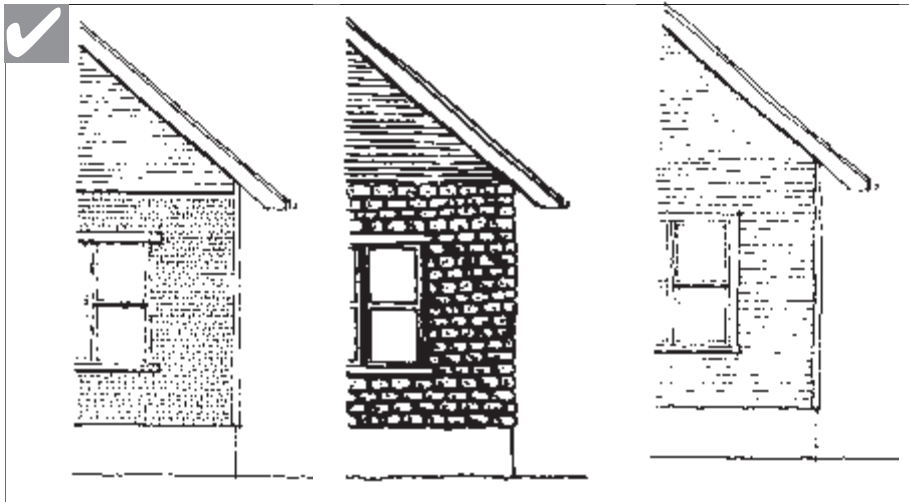

*Traditional materials include brick, stone and wood lap siding.*

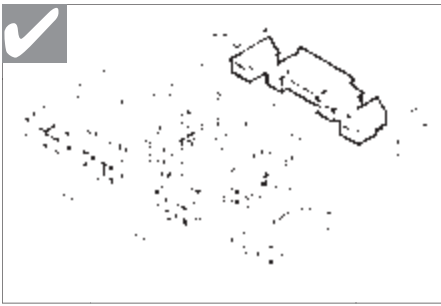

*This multi-household garage is well integrated into the surrounding garage structures. Notice the space being broken up into many units.*

8. **Orient a primary entrance to the street, when feasible.**
  - This should be similar in scale to traditional single household entries.
9. **Provide some useful, functional common open space that can be enjoyed by all residents in the development.**
  - Functional and useful open space should be designed to meet the activity needs of residents and should have dimensions and design treatments that accommodate these activities. It should not be left over space, not considered in the design.
  - The building forms should be arranged to define private yards.
  - This space should be provided in addition to the more public front yard.
10. **Minimize the visual impacts of multi-household garages.**
  - If enclosed parking is provided, consider locating it in a detached garage on the alley, when feasible.
  - In a larger structure that includes parking, consider breaking up the mass of the building and its roof forms to minimize its visual impact.
  - Locating enclosed parking in the front facade of a multi-household building is inappropriate. Doing so may increase the perceived mass and scale of the structure as a whole.
11. **Design a surface lot with landscaping.**
  - In a case where more than three parking spaces must be accommodated in the rear yard off the alley, landscaping should be provided between every second car to provide visual relief and to maintain pedestrian access to the alley from rear yards.
  - Where more than one parking space is located parallel to the alley, a landscape buffer should be provided between the alley and the parking space.
  - Also, minimize the amount of area that is paved for parking and consider using a variety of paving materials to distinguish parking spaces.

## F. Fences and Retaining Walls

### Policy:

Traditionally front yard fences were relatively low in height and had a “transparent” character that allowed views into yards, providing interest to pedestrians. Solid plank wood fences were used occasionally along alley edges, but also were relatively low in height. A new or replacement fence should be similar in character with those used traditionally in the neighborhood. In addition, fences should relate in character to the principal structures on the lot.

In some areas retaining walls are also found. They typically align along the edges of sidewalks, and help to establish a sense of visual continuity and should be maintained.

### Guidelines:

1. **A new fence should be in character with those seen traditionally.**
  - A fence that defines the front yard is usually low to the ground and “transparent” in nature.
  - Chain link and solid “stockade” fences are discouraged in front yards.
  - Painted wood picket, simple wire and ‘wrought iron’ fences are appropriate materials.
  
2. **A new retaining wall should be in character with those seen traditionally.**
  - A retaining wall that defines the sidewalk edge or is used in the front yard should not exceed 36 inches.
  - Use similar materials that are similar to those used traditionally, such as cut rock and stone. In some cases concrete may be an appropriate material.

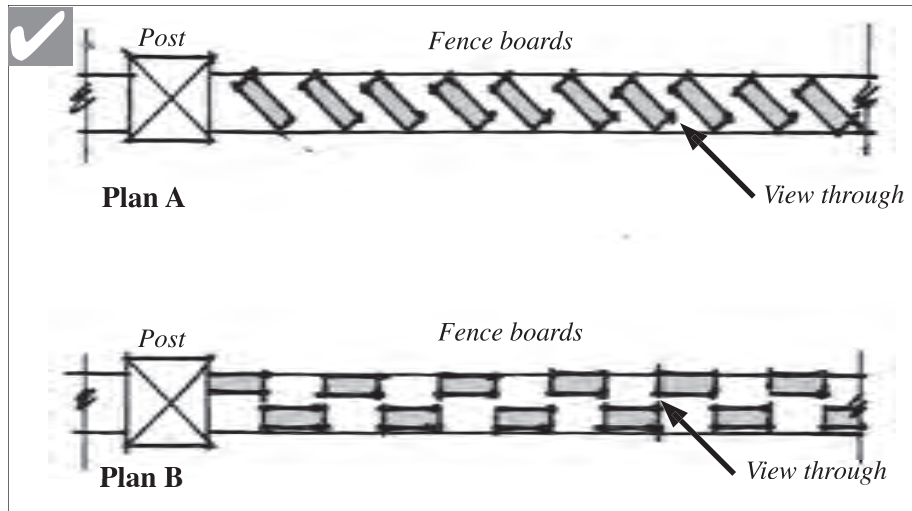

The fencing plans show how a side or rear yard fence can appear more “transparent”. Plan A shows the fence boards slanted at a 45 degree angle. Plan B shows the fence boards altering between front and back plane. Both plans allow for views into yard.



Traditionally front yard fences were relatively low in height and had a “transparent” character that allowed views into yards, providing interest to pedestrians as shown in these early sketches.



*The fence in the image above is in character with those seen traditionally.*

# CHAPTER 4

# GUIDELINES FOR THE

# COMMERCIAL CHARACTER AREA



*Main Street Historic District*

## **In this Chapter:**

- A. Mass and Scale
- B. Building and Roof Form
- C. Building Setbacks
- D. Horizontal Alignment
- E. New Storefront Character
- F. Parking Facilities
- G. Site Furniture
- H. Awnings and Canopies
- I. Signs

This chapter discusses the guidelines for new commercial properties.

Subchapter 4B was added by Resolution 4598 on May 18, 2015.

# CHAPTER 4

## GUIDELINES FOR THE COMMERCIAL CHARACTER AREA

### A. Mass and Size

#### Policy:

Patterns are created along the street by the repetition of similarly-sized building elements. For example, uniform facade widths evenly spaced along Main Street create a rhythm that contributes to the visual continuity of the district. At a smaller size, the repetition of upper-story windows across most building fronts also creates a unifying effect. These features and similar patterns are some of the most important characteristics of the commercial character areas and should be respected in all new construction.

1. **Maintain the average perceived size of buildings at the sidewalk.**
  - Facade heights of new buildings should fall within the established range of the block, and respect the historic proportions of height to width.
  - Floor-to-floor heights should appear similar to those of historic buildings in the area.
  
2. **Traditional spacing patterns created by the repetition of uniform building widths along streets must be maintained.**
  - In most cases, a facade should not exceed 50 feet without a clear expression of this standard module. One of several exceptions may be a one-story warehouse type buildings that could be located along Mendenhall and Babcock.
  - Where a building must exceed this width, use a change in design features to suggest the traditional building widths. Changes in facade material, window design, facade height or decorative details are examples of techniques that may be considered. These variations should be expressed through the structure such that the composition appears to be a collection of smaller building modules.



*New construction should appear similar in mass and scale to nearby historic structures.*



*Use building forms similar to those found traditionally. Rectangular shapes are typical and are encouraged.*

3. **A new building should incorporate a base, middle and a cap.**
- Traditionally, buildings were composed of these three basic elements. Interpreting this tradition in new buildings will help reinforce the visual continuity of the area.

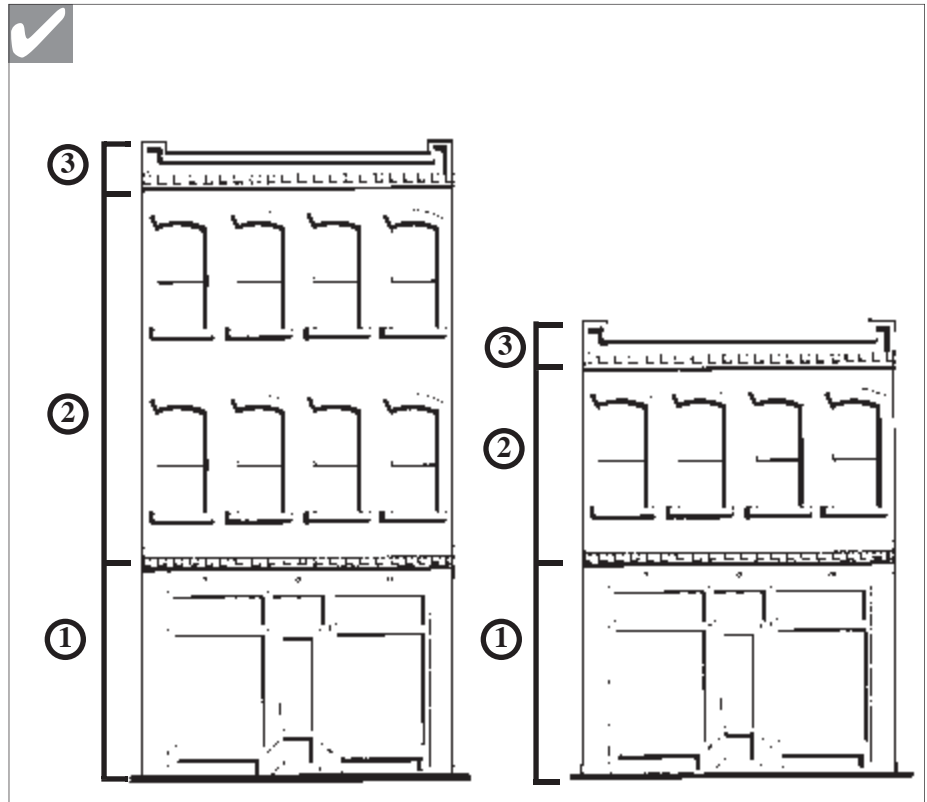

*These two building models incorporate these basic building elements: (1) base, (2) middle and (3) cap.*

## B. Building and Roof Form

### Policy:

One of the most prominent unifying elements of the commercial area is the similarity in building form. Commercial buildings were simple rectangular solids, deeper than they were wide. This characteristic is important and should be continued in new projects.

#### 1. Rectangular forms should be dominant on commercial facades in the Main Street Historic District.

- Rectangular forms should be vertically oriented.
- The facade should appear as predominantly flat, with any decorative elements and projecting or setback “articulations” appearing to be subordinate to the dominant form.

#### 2. Use flat roof lines as the dominant roof form in the Main Street Historic District.

- Gabled roofs on the main building may also be used if a false front or parapet with horizontal emphasis obscures it. They may also be used on upper story additions if they are set back from the primary facade.
- Gable roof forms may also be appropriate along buildings that face Mendenhall and Babcock.

#### 3. Along rear facades that abut residential neighborhoods, a building form should step down in size, and not be a continuous facade plane.

- Consider using additive forms, such as sheds, stairs and decks. These forms must, however, remain subordinate to the primary structure.
- Use projecting roofs at the ground floor over entrances, decks and separate utility structures to establish a human scale that invites pedestrian activity.



*Buildings located in the transition zone between Main Street commercial buildings and the residential neighborhood have more flexibility in their roof form. For example, gable roofs in these areas are appropriate.*



*Express the distinction in floor heights between the street and upper levels through detailing, materials and fenestration. The presence of a belt course is an important feature in this relationship.*



*Maintain the distinction between the street level and the upper floor. Also to note is the transition of the building to residential character.*



*A strong alignment of horizontal elements exists along the street, this quality should be maintained.*



*Maintain the alignment of buildings at the sidewalk edge.*

*The alignment of horizontal features on building facades is one of the strongest characteristics of the street and should be maintained. It is important to note, however, that slight variations do occur, which add visual interest. For example, the third floor and main entrance in this building show where a variation has occurred.*

## C. Building Setbacks

### Policy:

Buildings create a strong edge to the street because they traditionally aligned on the front lot line and were usually built out the full width of the parcel to the side lot lines. Although small gaps do occur between some structures, they are the exception. These characteristics are vitally important to the Main Street Historic District and in areas abutting the district where a street wall is a prominent feature.

#### 1. **Maintain the alignment of facades at the sidewalk's edge.**

- Place the facade of the building at the property line. This should only vary in special circumstances.
- Locating entire building fronts behind the established storefront line is inappropriate.

## D. Horizontal Alignment

### Policy:

A strong alignment of horizontal elements exists along the street. Alignment is seen at the first floor level with moldings that are found at the top of display windows; at upper floor levels, alignment is found among cornices, window sills and headers. This alignment of horizontal features on building facades is one of the strongest characteristics of the street and should be preserved. It is important to note, however, that slight variations do occur, which add visual interest. Major deviations from these relationships, however, disrupt the visual continuity of the street and are to be avoided.

#### 1. **The general alignment of horizontal features on building fronts must be maintained.**

- Typical elements that align include: window moldings, tops of display windows, cornices, copings and parapets at the tops of buildings.
- When large buildings are designed to appear as several buildings, there should be some slight variation in alignments between the horizontal facade elements.



## E. New Storefront Character

### Policy:

The street level floors of historic Bozeman commercial buildings are clearly distinguishable from the upper floors. First floors are predominantly fixed plate glass with a small percentage of opaque materials with recessed entries. Upper floors are the reverse—opaque materials dominate, and windows appear as smaller openings puncturing the solid walls. These windows are usually double-hung. The street level is generally taller than the upper floors. Store fronts of 12 to 14 feet high are typical, whereas second floors of 10 to 12 feet are typical. This typical storefront character should be maintained.

- 1. Maintain the traditional spacing pattern created by upper story windows.**
  - Maintain the historic proportions of windows.
  - Headers and sills of windows on new buildings should maintain the traditional placement relative to cornices and belt courses.
- 2. Maintain the distinction between the street level and the upper floor.**
  - The first floor of the primary facade should be predominantly transparent glass.
  - Upper floors should be perceived as being more opaque than the lower floor.
  - Highly reflective or darkly tinted glass is inappropriate.
  - Express the distinction in floor heights between street levels and upper levels through detailing, materials and fenestration. The presence of a belt course is an important feature in this relationship.
- 3. Maintain the pattern created by recessed entryways.**
  - Set the door back from the front facade an adequate amount to establish a distinct threshold for pedestrians. A recessed dimension of four feet is typical.
  - Where entries are recessed, the building line at the sidewalk edge should be maintained by the upper floor(s).
  - Use transoms over doorways to maintain the full vertical height of the storefront.
  - Oversized (or undersized) interpretations are discouraged.



*The first floor of a commercial building should be primarily transparent.*



*Maintain the pattern created by recessed entries.*



*Design a parking structure so that it creates a visually attractive and active street edge.*



*New parking facilities should be designed to be attractive, compatible additions to a commercial area. Using high quality materials, providing a sense of scale in architectural details and providing active uses at the sidewalk edge are methods that can mitigate the potentially negative impacts of new parking facilities.*



*A successful method in creating an attractive street edge includes providing display cases.*

## F. Parking Facilities

### Policy:

New parking facilities should be designed to be attractive, compatible additions to the streetscape. Using high quality materials, providing a sense of scale in architectural details and providing active uses at the sidewalk edge are methods that can mitigate the potentially negative impacts of new parking facilities. In general, a new parking facility should remain subordinate to the street scene. Parking structures should be designed to enhance the activity of the streetscape. At a minimum, a parking structure should help to animate the street and be compatible with the surroundings. The visual impact of the cars themselves should be minimized.

### Guidelines:

#### 1. Design a parking structure so that it creates a visually attractive and active street edge.

- When feasible, a parking structure in the area should be wrapped with retail, commercial or another active use along the street edge to separate the facility from the street and to add activity to the street.
- Other methods of accomplishing this include, but are not limited to:
  - Retail/commercial wrap
  - Murals or public art
  - Landscaping
  - Product display cases

#### 2. A parking structure should be compatible with traditional buildings in the surrounding area.

- Respect the regular window pattern and other architectural elements of adjacent buildings.
- Maintain the alignments and rhythms of architectural elements, as seen along the street.
- Continue the use of similar building materials.
- Avoid multiple curb cuts. These complicate turning movements and disrupt the sidewalk.
- Express the traditional widths of buildings in the area.



*New parking facilities should be designed to be attractive, compatible additions to the streetscape.*

## G. Site Furniture

### Policy:

Site furnishings, including bicycle racks, waste receptacles and light standards, are features of contemporary life in Bozeman. Few of these elements appeared historically in the community and it is important that the character of these elements not impede one's ability to interpret the historic character of the area.

### Guidelines:

1. **Site furniture should be simple in character.**
  - Avoid any highly ornate design that would misrepresent the history of the area.
  - Benches, bike racks and trash receptacles are examples of site furnishings that may be considered.
  - In public open spaces within a project, trash and recycling receptacles should be placed near seating areas and at points of entry.

## H. Awnings and Canopies

### Policy:

Traditionally, awnings and canopies were noteworthy features of buildings in the downtown core and their continued use is encouraged.

### Guidelines:

1. **A fabric awning is encouraged.**
  - Operable awnings are appropriate.
2. **A fixed metal canopy may be considered.**
  - Appropriate supporting mechanisms are wall mounted brackets and chains.
3. **The awning and canopy should be in character with the building and streetscape.**
  - Mount an awning or canopy to accentuate character-defining features. The awning or canopy should fit in the opening of the buildings.
  - Use colors that are compatible with the overall color scheme of the facade. Solid colors are encouraged.
  - Simple shed shapes are appropriate for rectangular openings. Odd shapes, bullnose awnings and bubble awnings are inappropriate.
  - Internal illumination of an awning is inappropriate.



*A fixed awning is appropriate.*



*An awning should fit within the storefront opening.*



*A flush-mounted sign should be subordinate to the overall building composition.*



*A window sign may be painted on the glass.*



*Where several businesses share a building, coordinate the signs in a directory.*

## I. Signs

### Policy:

All signs should be developed with the overall context of the building and the area in mind.

The placement or location of a sign is perhaps the most critical factor in maintaining the order and integrity of a commercial building. Consistent placement of signs according to building type, size, location and even building materials creates a visual pattern that the driver, or pedestrian, can easily interpret and utilize to the mutual benefit of merchants, tourists and customers.

### Guidelines:

1. **A flush-mounted or letter sign should be subordinate to the overall building composition.**
  - A sign should appear in scale with the facade.
  - Locate a sign on a building such that it will emphasize design elements of the facade itself. On a historic building a sign should not obscure architectural details or features.
  - Mount a sign to fit within existing architectural features. Use the shape of the sign to help reinforce the horizontal lines of moldings and transoms seen along the street.
2. **A window sign may be considered.**
  - A window sign may be painted on the glass or hung just inside a window.
3. **A projecting sign, which projects from the building front, may be considered.**
  - A small hanging sign is easier for a pedestrian to read than other sign types and is encouraged.
  - A small hanging sign should be located near the business entrance, just above the door or to the side of it.
  - A hanging sign should be mounted perpendicular with the building facade.
  - A hanging sign should provide clearance between the sidewalk surface and the bottom of the sign.
4. **Awning and canopy signs may be considered.**
  - Consider a canopy or awning sign where a flush-mounted sign would obscure architectural details.
5. **A directory sign may be considered.**
  - Where several businesses share a building, coordinate the signs. Align several smaller signs, or group them into a single panel as a directory.
  - Use similar forms or backgrounds for the signs to tie them together visually and make them easier to read.

6. **A pole mounted or monument sign may be considered.**
- A freestanding sign may be used in areas where buildings are primarily set back from the street edge. For example, a freestanding sign may be used in the front yard of a residence with an accessory commercial use.
  - A monument sign may be used in areas where buildings are primarily set back from the street edge.
  - A pole mounted or monument sign in the Main Street historic district would be inappropriate.
7. **Using a symbol for a sign is encouraged.**
- A symbol sign adds interest to the street, can be read quickly and is remembered better than written words.



*Locate a sign on a building such that it will emphasize design elements of the facade in a subordinate manner.*



Signs which have historical or cultural significance to the City but do not conform to the provisions of the UDO may be permitted provided that the city Commission adopts findings supporting the historical or cultural significance of the sign and issues a sign permit. For more information contact the Department of Planning and Community Development.



*Many good examples of old and new projecting signs are located along Main Street.*

## SUBCHAPTER 4-B GUIDELINES FOR THE B-3 COMMERCIAL CHARACTER AREA

Downtown Bozeman should be the location of buildings of greatest height and intensity in the community. The following guidelines apply to properties zoned B-3 (Central Business District) that serves as a transition between the Main Street Historic District and residentially zoned neighborhoods. Underdevelopment of this transitional zone is a major concern. The downtown district is planned for continued intensification over time with building additions as well as new construction replacing dilapidated and underutilized older structures on underdeveloped properties. Housing—for all income levels—should be encouraged by a variety of methods to support the continued economic vitality of the Downtown Bozeman business district, which is broadly recognized as one of Bozeman’s strongest assets.

This chapter contains guidelines for new commercial, residential and mixed use development located within B-3 zoned areas outside of the defined Main Street Historic District, as shown in Figure 1.1. Note that buildings individually listed on the National Register of Historic Places or within designated historic districts are subject to chapters one, two and four, but not this subchapter.

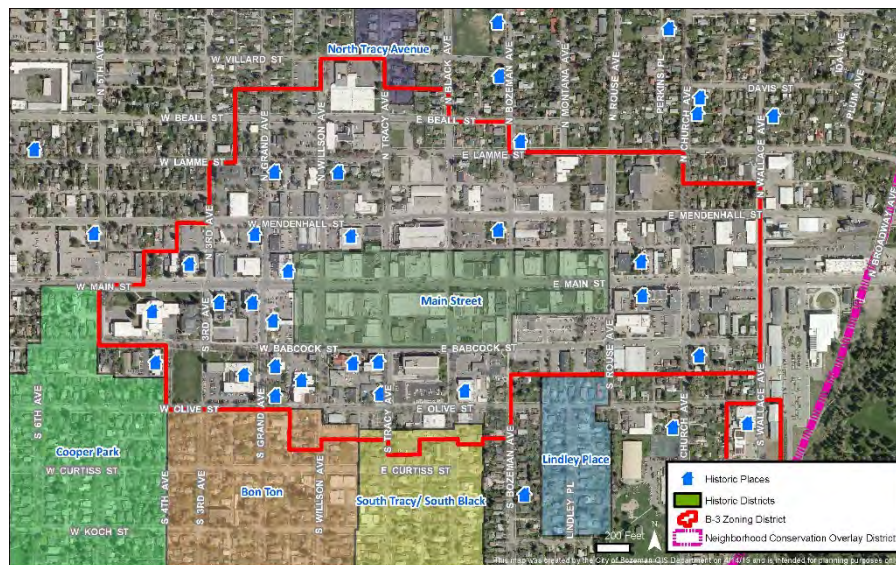

Figure 1.1 B-3 District surrounding the Main Street Historic District

**In this Subchapter:**

- A. Mass and Scale**
- B. Building Quality**
- C. Building Roof Form**
- D. Site Design**
- E. Parking Facilities**
- F. Signs**
- G. Street Patterns**
- H. Landscape Design**
- I. Site Lighting**
- J. Utilities and Service Areas**
- K. Site Furniture**



NO

## A. Mass and Scale

**Policy:** The scale and character of the Main Street Historic District should be protected. The area covered under this subchapter, should be able to accommodate compatible contemporary development of greater height and density. Varied mass and scale along a streetscape and block is inevitable and can contribute to a more interesting urban pattern that continues to evolve over time.

### 1. Provide density to meet the goals and objectives of the Downtown Bozeman Improvement Plan. .

- Floor area ratio for any new construction project shall be a minimum of 1.0 FAR. Lower FAR ratios are acceptable with renovation or remodeling of existing structures.
- Floor-to-floor heights for commercial and mixed use buildings shall be designed to accommodate a variety of current and future uses. The first floor level of new commercial and mixed use buildings shall maintain a minimum floor-to-floor height of 15 feet.
- Buildings with 100 percent residential uses are exempt from the 15 foot floor-to-floor height requirement but are encouraged to consider taller first floors to provide flexibility for a variety of uses over time.

### 2. Innovative development and diversity of design is encouraged.

- Buildings and streetscapes should be of high quality and reflect a variety of architectural styles.
- Decorative architectural adornment or other architectural patterns that convey a false sense of historic period are discouraged.
- Buildings and additions should undergo a critical and rigorous design process by design professionals that includes an emphasis on best practice designs to address sustainable development.
- Innovative use of varied materials is encouraged.

### 3. A new building should exhibit clear order and comprehensive composition on all elevations.

- Entire facades of a single surface are discouraged. A combination of materials and articulation of building elements shall be expressed in the proposed architectural character.
- Layering of design elements is encouraged.
- A clear narrative of the design process and intent and compliance with these guidelines shall be included in the application. The narrative shall address these guidelines and may propose alternative method(s) of compliance that clearly meet the intent of these guidelines. Alternate proposals may be approved by the Director of Community Development.

•

#### 4. **Building interface with residential zone properties.**

- Building facades along alleys shall incorporate a variety of materials and incorporate elements, including windows, to provide visual interest to minimize the massing and scale of the building.
- Building sites that abut or are across an alley from a residential zone district shall be sensitive to the interface where the properties meet by meeting the required setback from the residentially zoned property and providing a transition zone.
  - Along the interior side or rear property line, commencing at a vertical height of 44 feet the building shall step back at an angle no greater than 45 degrees.
  - Commercial zoned properties that abut residential zoned properties shall be exempt from the step back and height transition zone requirements if: the commercial and residential zoned lots are under unified ownership and are being developed under a master site plan.
- Primary entries to buildings shall be clearly identifiable from the street.
- Large expanses of glass as a building façade treatment is discouraged.

#### 5. **Building Quality**

**Policy:** New buildings shall be designed to a high level of permanence and quality.

1. **New buildings shall be designed to the level of permanence and quality appropriate for Downtown Bozeman.**
2. **Sustainable methods and techniques shall be applied to building design but also integrated with site layout and infrastructure design.**

### C. **Building Roof Form**

**Policy:** Roof forms should be primarily flat roofs with other roof forms that fit to the architectural character of the application.

#### 1. **Use flat roof lines as the primary roof form.**

- Rooftop balconies and decks are encouraged.
- Green roofs are encouraged.
- Mechanical equipment should be located on the roof when feasible. Solar applications are encouraged to screen other mechanical equipment.



## 2. The use of other roof forms.

- Depending on the architectural style and site context, a variety of other roof forms may also be appropriate.

## D. Site Design

**Policy:** All sites in downtown should be designed to make the experience of pedestrians and bicyclists safe, comfortable and visually appealing.

### 1. Create strong connections between downtown's sub-districts, and between downtown and the surrounding neighborhoods.

- Place the facade of the building at the minimum front setback line except when creating a public space.
- Commercial building facades along secondary (local) streets shall enhance the pedestrian experience by providing street level facades with a minimum of 50% transparent windows.

### 2. Public spaces should be made active through programming or utilizing opportunities with adjacent uses that promote vitality and safety.



## E. Parking Facilities

**Policy:** Minimize the visual impacts of parking.

1. **Enclosed parking, integrated into individual new buildings as well as additions (if feasible), is preferred whenever possible to surface parking lots.**
  - Considerations should be given to both on-grade or subgrade options.
2. **Shared parking structures are preferred to surface parking lots. A parking structure should be designed so that it creates a visually attractive and active street edge.**
  - A parking structure in the area should enhance the streetscape by being wrapped with commercial uses or another active use along the street edge to separate the facility from the street and to add activity to the street.
  - Other methods of accomplishing this include, but are not limited to
    - Murals or public art
    - Landscaping and urban plazas
3. **For residential projects, enclosed parking is preferred to surface parking lots.**
  - If individual enclosed parking is provided, consider locating it in a garage accessed internally or from an alley, when feasible.

- Locating enclosed parking on the front facade of a multi-household building is inappropriate. Doing so may increase the perceived mass and scale of the structure as a whole.

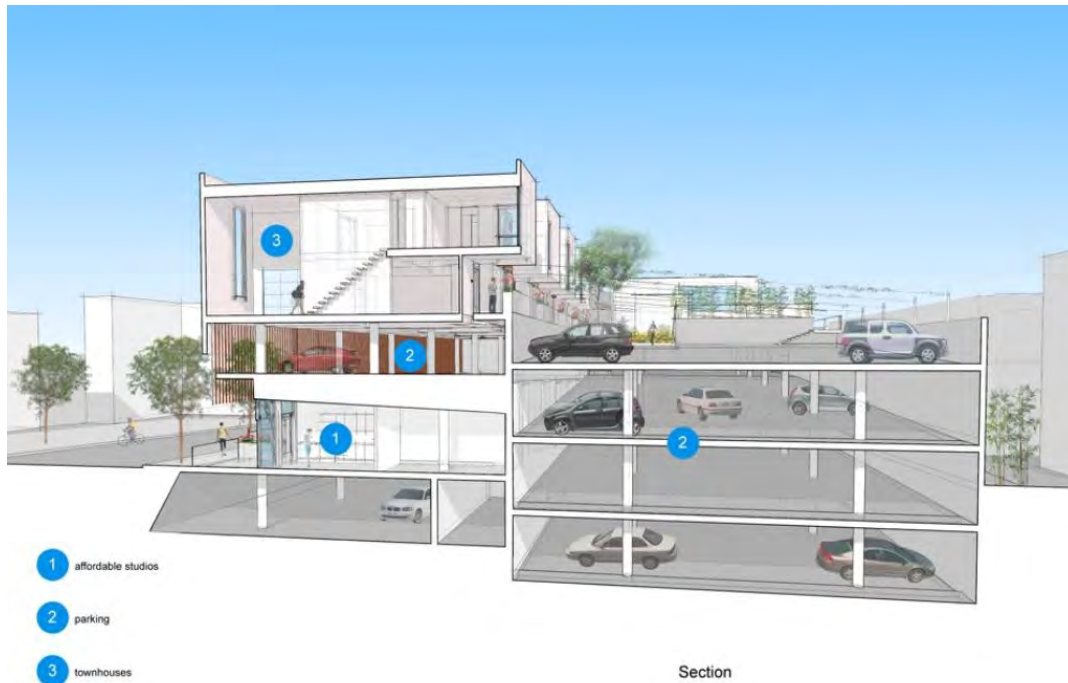

## F. Signs

**Policy:** All signs should be designed to fit the overall context of the building and the district.

### 1. Commercial and Mixed Use projects should include a variety of creative and clear signage.

- Wall-mounted and projecting signs, as well as canopy and awning signs in some circumstances are preferred.
- Directory signs support a pedestrian scale and are strongly encouraged where appropriate.
- Artful, whimsical and creative signage is encouraged. A comprehensive sign plan may be required; however, it is not intended to promote monotony.

### 2. Residential projects are encouraged to include building identification signage to add to Bozeman's overall sense of place.

- Wall-mounted signage is most appropriate.
- Artful, whimsical and creative signage is encouraged.

**3. All signs should be developed with the overall context of the building and the area in mind. The placement or location of a sign is a critical factor in maintaining the order and integrity of a building. Consistent placement of signs according to building type, size, location and even building materials creates a visual pattern that enhances the streetscape experience.**

- a. A flush-mounted or letter sign should be subordinate to the overall building composition.
  - A sign should appear in scale with the facade.
  - Locate a sign on a building such that it will emphasize design elements of the facade itself.
  - Mount a sign to fit within existing architectural features.
  - Use the shape of the sign to help reinforce the design elements of the building.
- b. A window sign may be considered.
  - A window sign may be painted on the glass or hung just inside a window.
- c. A projecting sign, which projects from the building front, may be considered.
  - A small hanging sign is easier for a pedestrian to read than other sign types and is encouraged.
  - A small hanging sign should be located near the entrance, just above the door or to the side of it.
  - A hanging sign should be mounted perpendicular with the building facade.
  - A hanging sign should provide clearance between the sidewalk surface and the bottom of the sign.
- d. Awning and canopy signs may be considered.
  - Consider a canopy or awning sign where a flush-mounted sign would obscure architectural details.
- e. A directory sign may be considered.
  - Where several businesses share a building, coordinate the signs. Align several smaller signs, or group them into a single panel as a directory.
  - Use similar forms or backgrounds for the signs to tie them together visually and make them easier to read.
- f. A pole mounted or monument sign may be considered.
  - A freestanding sign may be used in areas where buildings are primarily set back from the street edge. For example, a freestanding sign may be used in the front yard of a residence with an accessory commercial use.
  - A monument sign may be used in areas where buildings are primarily set back from the street edge.
- g. Using a symbol for a sign is encouraged.
  - A symbol sign adds interest to the street, can be read quickly and is remembered better than written words.



## G. Street Patterns

**Policy:** Historic settlement patterns seen in street and alley plans often contribute to the distinct character of the downtown and therefore they should be preserved. These street plans influence the manner in which primary structures are sited and they also shape the manner in which landscape features may occur on the site.

### *Alleys*

**Policy:** Alleys accommodate service functions and provide pedestrian connections and secondary vehicle access. All alleys contribute to the character of the district.

1. The traditional scale and width of alleys should be continued.

Maintain the traditional character and scale of an alley by locating buildings and fences along the alley edges to maintain the alley edge.

### *Streetscape*

**Policy:** Maintain the character of the streetscape. This includes a rich collection of varying street designs, sidewalk types and street trees.

Guidelines:

1. Maintain the variety of street paving designs.
2. Consider utilizing the variety of sidewalk designs.
  - Where a detached (sidewalks separated from the street by a strip of grass) sidewalk exists, it should be preserved.

- Where no sidewalk exists a new sidewalk is required; it should be constructed to be in character with the traditional sidewalks in the neighborhood.
2. Use of planting strips is encouraged.
    - Planting strips should act as a transition between public and semipublic spaces.
    - Where planting strips between the curb and sidewalk exist they should be maintained.
    - If new detached sidewalks are installed new planting strips should be provided.
  3. Continue the pattern of street trees in a block. Because street trees serve various aesthetic and practical functions, they should be maintained.
    - Existing street trees should be preserved, when feasible.
    - If a new detached sidewalk is to be created, street trees should be an accompanying feature.
    - If a new sidewalk is to be installed, it should detour around mature street trees, when feasible.
    - When an existing street tree dies, it should be replaced.
    - Any new developments should include street trees.
    - The historic urban design character for street tree placement should be considered when enforcing city street standards.

## ***H. Landscape Design***

Policy:

Landscaping enhances the built environment. Plant beds near and around building foundations and along walkways are encouraged. Some sites may contain plantings that have historic significance and should be retained, to the extent feasible. Some mature trees may also contribute to the historic landscape and should be preserved.

Guidelines:

1. Preserve and maintain mature trees and significant vegetation that are a direct enhancement of the pedestrian streetscape environment.
  - Include existing vegetation as a part of a landscape design scheme where appropriate.
  - In re-development areas, retention of healthy trees and vegetation clusters should be given consideration for retention to the maximum extent possible, especially mature trees, 6" or greater in diameter, and to vegetation clusters with significant visual impact.

## ***I. Utilities and Service Areas***

Policy: Service areas should be visually unobtrusive and should be integrated with the design of the site and the building.

Guidelines:

1. Orient service entrances, waste disposal areas and other similar uses toward service lanes and away from major streets.

- Screen service entrances with walls, fences or plantings.
  - When it will be visible from a public way, a service area screen should be in character with the building and site it serves.
  - Areas for outdoor storage, truck parking, trash collection or compaction loading, or other such uses shall be located so as not to be visible from abutting streets.
2. Position service areas to minimize conflicts with other abutting uses.
    - Minimize noise impacts by locating sources of offensive sounds away from other uses.
    - Use an alley system to locate service areas, when feasible.

## ***J. Site Furniture***

Policy: Site furnishings, including bicycle racks, waste receptacles and light standards, are features of contemporary life in Bozeman. Few of these elements appeared historically in the community and it is important that the character of these elements not impede one's ability to interpret the historic character of the area.

Guidelines:

1. Site furniture should be simple in character.
  - Avoid any highly ornate design that would misrepresent the history of the area.
  - Benches, bike racks and trash receptacles are examples of site furnishings that may be considered.
  - In public open spaces within a project, trash and recycling receptacles should be placed near seating areas and at points of entry.



## CHAPTER 5

# DISTRICT SPECIFIC DESCRIPTIONS



*Story Mill Historic District*

## **In this Chapter:**

- A. Northern Pacific/Story Mill Historic District
- B. Bozeman Brewery Historic District
- C. North Tracy Historic District
- D. Main Street Historic District
- E. Cooper Park Historic District
- F. Lindley Place Historic District
- G. Bon Ton Historic District
- H. South Tracy/ South Black Historic District
- I. South Tracy Historic District

This chapter includes brief district-specific descriptions as well as maps outlining the regions described. These apply in addition to the general design guidelines in the proceeding chapters.

# CHAPTER 5

## DISTRICT SPECIFIC DESCRIPTIONS

### A. Northern Pacific/Story Mill Historic District

The Northern Pacific/Story Mill Historic District is located in the northeast corner of Bozeman, Montana, and contains the Northern Pacific Main Line, the Northern Pacific Rail Yard, the Story Mill Spur Line and several associated buildings, structures and sites. The district is L-shaped and contains industrial warehouse structures, rail yard structures and rural building types. One of the few industrial areas in the Gallatin Valley, the Story Mill Historic District is clearly distinguished from its surroundings by its patterns of development and association. The rural property and the light industrial area are linked by the Northern Pacific's Story Mill Spur Line.

The industrial area along Front Street has heavily impacted the surrounding area. Within a two block corridor centered along the spine of the railway, light industry has been established. Many of the structures are located outside of the district but influence the context in which the Story Mill district is located. The warehouse buildings are arranged in a grid formation and come in contact with the Bozeman creek in the north section of the warehouse industrial area. Many of these structures are historically significant and their integrity should be preserved.

Within the northern "rural" arm of the district, the Story Mill Complex adds great historical value to the area. The structures consist of metal clad, wood frame, stone and stucco. As the undisputed transportation hub of southwestern Montana's impressive agricultural economy, the Story Mill Historic District



*The Historic Story Mill complex uses many different materials such as wood, metal, and stone.*



*Story Mill Historic District*



*Build upon the “industrial style” architecture that exists along the Story Mill Historic District.*

is reflective of broad historic patterns of commerce, travel, and settlement, and, therefore, qualifies for National Register listing. The Story Mill Historic District is a well-preserved example of a historic center of transportation and commerce.

**Period of Significance: 1882-1945**

**District Character:**

- variation in lot sizes
- industrial and rural “backroad” setting
- simple building forms
- clustered mill buildings in rural setting
- industrial buildings located within an established grid

**Guidelines:**

- 1. Build upon the “rural and industrial style” architecture that exists in and around the Story Mill Historic District.**
  - Consider the use of wood cladding, corrugated sheet metal, concrete or brick materials.
  - Consider developing a design palette for new construction that draws from design elements and materials found in traditional ranch, mill or industrial building types, use these elements in the appropriate context.
  - Use simple rectangular building forms.
- 2. Reduce the visual impact of industrial operations.**
  - Provide landscape buffers for equipment and product storage.
  - Service areas that involve the transfer of goods should also be screened from view.
  - Emphasize street frontage landscaping and its protection from truck movement by installing curbs in any new development or redevelopment.
- 3. Retain the existing mill complexes as dominant buildings within the district area.**
  - New construction should remain subordinate in mass, scale and height to historic mill complexes within the district area.



*Maintain the rural character within the north arm of the district.*

## B. Bozeman Brewery Historic District

The district is located in the northeastern corner of the city near the Northern Pacific Railroad depot. The Bozeman Brewery Historic District is composed of six historic buildings that are directly associated with the Julius Lehrkind mansion and the family owned and operated Bozeman Brewery business. The remains of the brewery, a four-story brick structure, stands at the north end of the district. Across the street is the one-story, brick bottling plant. To the south of these two industrial buildings is the Lehrkind family compound, consisting of the large, Queen Anne style Julius Lehrkind House, and the more modest houses of Henry Lehrkind and Edwin Lehrkind, which were built a decade later.

All of the buildings included within the district retain a high degree of historic integrity, with the exception of the Brewery building. The other structures in the district are important to Bozeman's industrial, social and ethnic history. The district is representative of the heightened technological developments in the beer making industry at the time.

### Period of Significance: 1895-1925

#### District Character:

- variation of building types; simple masonry building forms for industrial uses
- buildings address the street

#### Guidelines:

1. **Reflect the district character when building within and around the district.**
  - Consider the use of brick materials.
  - Consider developing a design palette for new construction that draws from design elements and materials found in the area.
  - Use simple rectangular building forms.
2. **Retain the existing Lehrkind mansion as the dominant residential building within the area.**



*Bozeman Brewery Historic District.*



*The Queen Anne Style Julius Lehrkind House.*



*This building reflects the district's industrial character. Brick was the predominant material on the brewery building.*



*North Tracy Historic District.*



*Here the sense of rhythm is seen through a consistent set back from the street.*



*Preserve original porch materials.*



*Garages should remain subordinate to the primary structure on the site and should be located to the rear of the building. Note the character of the two-track driveway.*

## C. North Tracy Avenue Historic District

The North Tracy Avenue Historic District contains the most significant concentration of historic residential architecture north of Main Street, and is a representative portion of what was once a quite extensive historic residential area. Some of the houses in the district are among the most significant examples of vernacular architecture in the city.

The North Tracy Avenue Historic District consists of 28 diverse, modest residences spanning two blocks, from Villard to Peach Streets. Although nine of the buildings are either neutral or non-contributing to the historic district, the district is nevertheless defined by its high overall architectural integrity and cohesiveness compared to surrounding streets. In addition, most of those nine retain enough of their original designs to maintain the historical continuity of the street. Of the contributing buildings in the district, eleven are Bungalow style and bear similar ornamentation, which helps to unify the district overall. The remaining nine are of diverse, 19th century forms, which display no specific stylistic elements. All but two houses are of frame construction, although several of them are covered with aluminum or asbestos siding.

The houses vary in size, design, and integrity, but are regularly spaced along the street and create a strong sense of rhythm along the full length of the historic district.

### Period of Significance: 1890-1930

#### District Character:

- residential neighborhood setting
- similar front yard setback
- simple one-story wood frame residential buildings
- porches address the street
- secondary structures & garages to the rear of the lot
- automobile access is provided by two track driveways

#### Guideline:

##### 1. Reflect the district character when building within and around the district.

- Consider the use of wood frame & siding materials.
- Consider developing a design palette for new construction that draws from design elements and materials found in the area.
- Use simple rectangular building forms with sloping roofs.

## D. Main Street Historic District

The Bozeman Main Street Historic District is the heart of the city of Bozeman and the Gallatin Valley. The district is composed of a virtually uninterrupted streetscape of commercial buildings along both sides of four blocks. The district stretches along a segment of the primary east-west thoroughfare in the city. It is bounded at either end by the two major city landmarks, the six-story Baxter and four-story Bozeman Hotels. With the exception of a few buildings on Tracy Avenue, a cross street, the entire district is visible from most points on Main Street.

The district consists of primarily two-story, 19th and early 20th century brick commercial blocks of varied design. Bands of colorful, irregular storefronts, canopies and signage unify all the buildings at street level. While few structures retain 100% integrity, most have regularly spaced windows and considerable ornamental detail, such as cornices and belt courses which lend a strong visual cohesion to the district overall.



Main Street Historic District

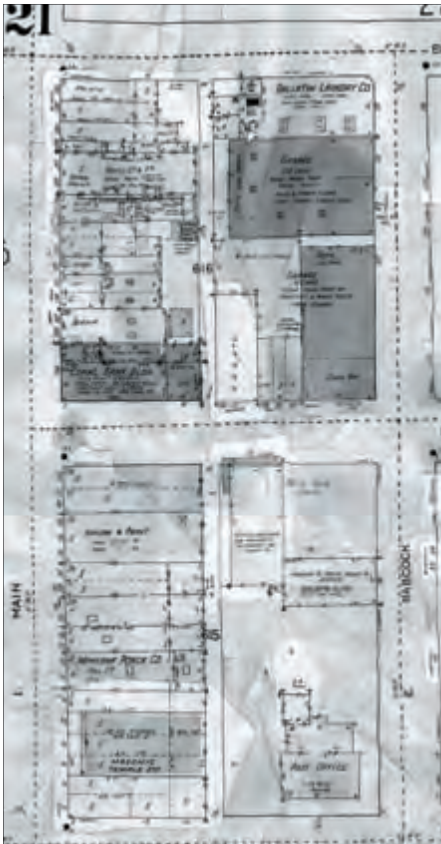

A 1947 Sanborn Fire Insurance map shows many planning characteristics that still define downtown Main Street today. This includes: buildings that align at the sidewalk, similar building facade widths, alley access and two-story buildings. Also note the transition zone between the alley behind Main Street, where large one-story warehouse buildings are located that typically abut staging or parking areas. Institutional buildings can also be found here, they are set back from the street and sit prominently on their site, they also have significantly less lot coverage, as do nearby residential buildings.



The National Bank of Gallatin Valley (1 W. Main) exhibits another unusual material-concrete blocks molded in imitation of rusticated masonry.



One of the most notable building examples from the 1900 -1930 is the glazed brick Baxter Hotel, an eclectic Art Deco form which dominates the western end of the district by its sheer size.



*The famous revolving horse.*

Several suspended signs in the district, while not eligible for the national register as contributing elements due to age, have significance of their own. These signs add color and relief to the streetscape, several signs of note include: Powderhorn Sporting Goods, Cosner Apartments and the famous revolving horse.

The Main Street District, with its tremendous diversity of architecture, has retained a high degree of cohesiveness overall.

### **Period of Significance: 1880's-1940**

#### **District Character:**

- main street commercial setting
- buildings align at the sidewalk
- simple rectangular building forms
- primarily flat roofs
- primarily masonry building materials
- first floor storefront
- large one-story warehouse buildings in transition area
- automobile and service access is provided off side streets & alley

#### **Guideline:**

- 1. Reflect the district character when building within and around the downtown area.**
  - Consider the use of masonry materials.
  - Consider developing a design palette for new construction that draws from design elements and materials found in the area.
  - Use simple rectangular building forms with flat roofs.
  - A diversity of building types is encouraged in the transition area between the Main Street District and nearby residential neighborhoods.

## E. Cooper Park Historic District

The Cooper Park Historic District, a large early 20th century residential area, contains about 250 diverse, one to two story frame houses with even spacing and setbacks, along level, tree-lined streets. The Bungalow style is clearly predominant in the district, though the eclectic Queen Anne and Colonial Revival styles, promoted by early 20th century pattern books, are also well represented. Architectural features such as exposed rafter tails, truss brackets, bay and oriel windows, porches, and a variety of surface textures and roof types lend both a strong visual cohesion and a distinctly Progressive Era character to the district.

While the district contains no examples of high style design, there are numerous excellent examples of vernacular architecture found within it. The architectural quality and integrity throughout the district is quite good, there being high percentage of significant buildings, and few gaps of non-contributing structures in the streetscapes. However, the level of architectural quality and pretension is highest in the immediate area of Cooper Park. A verdant, 2-block square open area in the western part of the district, Cooper Park is surrounded by large, well-spaced houses. The park serves as a focal point for the surrounding area and helps to break up the grid.

The Cooper Park Historic District, with its tremendous inventory of vernacular architecture has retained a high degree of cohesiveness.

### Period of Significance: 1885-1936

#### District Character:

- residential neighborhood setting
- similar front yard setback
- simple one-story wood frame residential buildings
- porches address the street
- secondary structures & garages to the rear of the lot
- automobile access is primarily from the alley



*Cooper Park Historic District.*



*Building setbacks are uniform on this block in the district, therefore new buildings should conform to this alignment.*



*The bungalow style is the predominate building style found within the district.*

**Guideline:**

- 1. Reflect the district character when building within the district.**
  - Consider the use of wood frame & siding materials.
  - Consider developing a design palette for new construction that draws from design elements and materials found in the area.
  - Use simple rectangular building forms with sloping roofs.



*A 1927 Sanborn Fire Insurance map of the Cooper Park Historic District shows many planning characteristics that still define the neighborhood today. This includes: buildings set back from the sidewalk, similar building facade widths and alley access. Building heights range from one, one and one-half and two-stories. Most buildings also show porch fronts and secondary buildings off the alley.*

## F. Lindley Place Historic District

The Lindley Place Historic District consists of a dense, very cohesive grouping of late 19th and early 20th century vernacular houses that line both sides of Lindley Place - an isolated, two block long street (which has no cross street) at the eastern edge of the city's residential grid. In addition, three simple Bungalows on the north side of Olive Street terminate the north end of the district. Behind the lots on the east side flows Bozeman Creek. East of that is the broad, open space of Bogart Park. While some houses have lost a degree of significance due to alteration such as application of non-original siding or removal of original features such as porches, the district in general is characterized by very high architectural integrity. There is a diversity of architectural styles found here including: Bungalows, Italianate, and Vernacular Queen Anne.

The ever-audible sound of Bozeman Creek, as well as amenities such as regularly spaced shade trees, concrete sidewalks imprinted with "Lindley Place - 1906" at the corner, a cast iron hitching post in the form of a horse head, together augment the unique, cohesive character of this small residential historic district.

### Period of Significance: 1880-1922

#### District Character:

- residential neighborhood setting
- similar front yard setback
- simple one and two-story wood frame residential buildings
- porches address the street
- secondary structures & garages to the rear of the lot
- automobile access is primarily from the alley

#### Guideline:

1. **Reflect the district character when building within the district.**
  - Consider the use of wood and masonry materials.
  - Consider developing a design palette for new construction that draws from design elements and materials found in the area.
  - Use simple rectangular building forms with sloping roofs.



*Front porches address the street.*



*Variety of lot sizes can be found.*



*Lindley Place Historic District*



*Regularly spaced trees define the canopy.*



*Diversity in building heights occur along the block.*



**District Character:**

- residential neighborhood setting
- similar front yard setback
- combination of elaborate and vernacular building styles
- porches address the street
- secondary structures & garages to the rear of the lot
- automobile access is primarily from the alley

**Guideline:**

**1. Reflect the district character when building within the district.**

- Consider the use of wood and masonry materials.
- Consider developing a design palette for new construction that draws from design elements and materials found in the area.
- Use simple rectangular building forms with sloping roofs.



*Regularly spaced trees define the streetscape canopy.*



*A diversity of building types can be found throughout the district.*



*South Tracy/South Black Historic District*



*The entrance into this house is an exception to the general front facing entrances as shown below.*

## H. South Tracy/South Black Historic District

The South Tracy-South Black Avenue Historic District consists of 93 diverse, vernacular houses lining S. Tracy and S. Black Avenues between Olive and Alderson Streets, as well as a large school building and a neighborhood grocery store. It is distinct from the two large, adjacent residential historic districts in Bozeman due to its greater building density and its high concentration of significant architecture of generally more modest scale and ornamentation. Many of the most significant buildings occur in pairs or groups of three, which heightens the overall visual impact of the district. Although many 19th century houses are found here, the numerous excellent examples of the Bungalow style are visually predominant. Overall, a continuous rhythm of regularly spaced houses along tree-lined streets act as a strong unifying element in the district.

Due to the scale, rhythm, and high concentration of significant historic architecture found along S. Tracy and S. Black Avenues, this district is visually distinct from all other residential areas in Bozeman. It also contains several fine examples of the earliest residential architecture in the city. Two of these are a pair of small, originally identical, 3x1 bay, jerkin head-roofed T-houses built in 1879 one of which retains its original Victorian period detailing. By the second decade the Queen Annes gave way to Bungalow style homes in this neighborhood.



*A 1927 Sanborn Fire Insurance map shows many planning characteristics that still define the South Tracy/South Black historic district today. This includes: buildings that are set back at a similar distance from the street, similar building facade widths and lengths, alley access behind some blocks, secondary buildings located to the rear, and front porches. Lot coverage is similar throughout the neighborhood.*

**Period of Significance: 1872-1939**

**District Character:**

- residential neighborhood setting
- similar front yard setback
- simple one and two-story wood frame residential buildings
- porches address the street
- secondary structures & garages to the rear of the lot
- automobile access is primarily from the alley

**Guideline:**

- 1. Reflect the district character when building within the district.**
  - Consider the use of wood and masonry materials.
  - Consider developing a design palette for new construction that draws from design elements and materials found in the area.
  - Use simple rectangular building forms with sloping roofs



*Regularly spaced trees define the streetscape canopy.*



*Numerous excellent examples of the Bungalow style are visually predominant.*



*Bungalow styles are visually predominant in the South Tracy district.*



*A shared drive lessens the impact of paving in the front yard, this is an appropriate approach.*



*Raised lawns contribute to the streetscape character of this historic neighborhood.*

## I. South Tracy Historic District

An island of Bungalows from the time of its initial construction in 1917 and well into the 1930's, the South Tracy Avenue Historic District remains a cohesive architectural unit, and a particularly vivid example of Bozeman's rapid early 20th century expansion. The seven similar, modest Bungalow style residences that make up the district, each of which has a separate garage behind it, represent the work of four local carpenters. Despite the extensive construction occurring throughout the city in the early 20th Century, this district remained an isolated unit, until the mid-1930's when construction began filling in the surrounding blocks.

The South Tracy Avenue Historic District, despite its small size, remains a strong, clearly defined group of buildings representing both the earliest period of automobile use, and a period of exponential growth in the city. Being surrounded by houses of much later and more diverse time periods, many of which have undergone extensive alteration in the past 20 years, the historic district retains a sense of its original isolation on South Tracy Avenue.

### Period of Significance: 1919-1923

#### District Character:

- residential neighborhood setting
- similar front yard setback
- simple one-story wood frame residential buildings
- porches address the street
- secondary structures & garages to the rear of the lot

#### Guideline:

1. **Reflect the district character when building within the district.**
  - Consider the use of wood materials.
  - Consider developing a design palette for new construction that draws from design elements and materials found in the area.
  - Use simple rectangular building forms with sloping roofs.



*South Tracy Historic District*

# APPENDIX A

## The Secretary of the Interior's Standards for Rehabilitation

1. A property shall be used for its historic purpose or be placed in a new use that requires minimal change to the defining characteristics of the building and its site and environment.
2. The historic character of a property shall be retained and preserved. The removal of historic materials or alteration of features and spaces that characterize a property shall be avoided.
3. Each property shall be recognized as a physical record of its time, place, and use. Changes that create a false sense of historical development, such as adding conjectural features or architectural elements from other buildings, shall not be undertaken.
4. Most properties change over time; those changes that have acquired historic significance in their own right shall be retained and preserved.
5. Distinctive features, finishes, and construction techniques or examples of craftsmanship that characterize a historic property shall be preserved.
6. Deteriorated historic features shall be repaired rather than replaced. Where the severity of deterioration requires replacement of a distinctive feature, the new feature shall match the old in design, color, texture, and other visual qualities and, where possible, materials. Replacement of missing features shall be substantiated by documentary, physical, or pictorial evidence.
7. Chemical or physical treatments, such as sandblasting, that cause damage to historic materials shall not be used. The surface cleaning of structures, if appropriate, shall be undertaken using the gentlest means possible.
8. Significant archeological resources affected by a project shall be protected and preserved. If such resources must be disturbed, mitigation measures shall be undertaken.
9. New additions, exterior alterations, or related new construction shall not destroy historic materials that characterize the property. The new work shall be differentiated from the old and shall be compatible with the massing, size, scale, and architectural features to protect the historic integrity of the property and its environment.
10. New additions and adjacent or related new construction shall be undertaken in such a manner that if removed in the future, the essential form and integrity of the historic property and its environment would be unimpaired.

# APPENDIX B

## Interpretation of Terms

These definitions apply to terms related to compliance in the preceding text.

**Appropriate.** In some cases, a stated action or design choice is defined as being “appropriate” in the text. In such cases, by choosing the design approach referred to as “appropriate,” the reader will be in compliance with the guideline. However, in other cases, there may be a design that is not expressly mentioned in the text that also may be deemed “appropriate.”

**Consider.** When the term “consider” is used, a design suggestion is offered to the reader as an example of one method of how the design guideline at hand could be met. Applicants may elect to follow the suggestion, but may also seek alternative means of meeting it. In other cases, the reader is instructed to evaluate the ability to take the course recommended in the context of the specific project.

**Context.** In many cases, the reader is instructed to relate to the context of the project area. The “context” relates to those properties and structures adjacent to, and within the same block as, the proposed project.

**Contributing Property.** A building that is identified as having significance and contributing to the character of a designated historic district is considered a “contributor.” These typically appear on an official survey of historic resources, but in some cases, significance may be determined at the time that an application for approval is submitted. Preservation of key defining features is the goal.

**Historically Significant Property.** Other older buildings that are found within the Conservation Overlay, but outside of any historic district. They are generally isolated buildings, in the context of newer structures, but sometimes they exist in a small grouping. If such a property is not of landmark quality, and it is not in the context of other similar properties, “conservation” of the overall character of the building is the focus.

**Non-historically Significant Property.** These are more recent properties, or older ones that are substantially altered, which lie within the Conservation Overlay, but outside of any historic district. The objective is to assure that, if altered or scraped, the result would be compatible with the context of the neighborhood, but preservation of features on the building itself is not a consideration.

**Historic Resource.** In general, a “historic resource” building is one that is 50 years old or older, associated with significant people or events or conveys a character of building and design found during the period of significance.

**Inappropriate.** Inappropriate means impermissible. When the term “inappropriate” is used, the relevant design approach will not be allowed. For example, one guideline states: “Enclosing a porch with opaque materials that destroy the openness and transparency of the porch is inappropriate.”

**Individual Listing.** A property that, on its own, has sufficient significance to be considered a historic resource may be designated an individual historic landmark. For these, preservation is an objective, and the guidelines for rehabilitation are to be applied rigorously. The design guidelines for all properties would also apply. And, if the landmark also lies within a historic district, the special neighborhood chapter would also apply.

**Non-historic.** Recent buildings and those 50 years old or older which have lost their integrity are considered “non-historic.” These buildings do retain property value, but do not possess the significance and/or physical integrity necessary to be considered a historic resource.

#### **Non-contributing Property**

A building found within a designated historic district, but which does not contribute to the significance of the district, is in this category. This may be a newer building that has not taken on significance, or it may be an older one that has been so substantially altered that it lacks integrity as a historic resource. The objective is to assure that, if altered or scraped, the result would be compatible with the historic context, but preservation of features on the building itself is not a consideration.

**Preferred.** In some cases, the reader is instructed that a certain design approach is “preferred.” In such a case, the reader is encouraged to choose the design option at hand. However, other approaches may be considered.

**Primary facade.** The primary facade is the principal elevation of a building, usually facing the street or other public way.

**Should.** If the term “should” appears in a design guideline, compliance is required. In cases where specific circumstances of a project make it impractical to do so, the City may determine that compliance is not required if the applicant demonstrates how the related policy statement still will be met.

**Traditional.** Based on or established by the history of the area.

# Appendix C

## Benefits of Historic Preservation

### A. Why Preserve Historic Resources?

Across the nation, thousands of communities promote historic preservation because doing so contributes to neighborhood livability and quality of life, minimizes negative impacts on the environment and yields economic rewards. Many property owners are also drawn to historic resources because the quality of construction is typically high and the buildings are readily adaptable to contemporary needs. These same reasons apply in Bozeman.

#### **Livability and quality of life**

When groups of older buildings occur in a conservation or historic district, they create a street scene that is “pedestrian friendly,” which encourages walking and neighborly interaction. Mature trees, decorative sidewalks and architectural features also contribute to a sense of identity that is unique for the neighborhood, an attribute that is rare and difficult to achieve in newer areas. This physical sense of neighborhood can also reinforce desirable community social patterns and contribute to a sense of security. Many residents of these districts, for example, note how easily they get to know their neighbors and praise the fact that they are recognized by others who live in their districts.

#### **Environmental benefits**

Preserving a historic structure is also sound environmental conservation policy because “recycling” saves energy and reduces the need for producing new construction materials. Three types of energy savings occur: First, no energy is consumed to demolish the existing building and dispose of the resulting debris. Second, energy is not used to create new building materials, transport them and assemble them on site. Finally, the “embodied” energy, that which was used to create the original building and its components, is preserved.

By “reusing” a historic building and the materials it was constructed with, pressure is also reduced to harvest new lumber and other materials that also may have negative effects on the environment of other locales where these materials are produced. Because older buildings can be quite energy efficient, heating and cooling needs may be reduced as well.

Living in traditional neighborhoods also helps reduce Bozeman’s dependence upon automobiles. Because these older places are in close proximity to the original downtown, they provide opportunities for many people to work, shop and seek entertainment close to where they live, and because commuting distances are reduced, so are vehicle miles traveled. A reduction in gasoline consumed and in air pollution from emissions discharged are therefore positive results of living in these neighborhoods.

## **Economic benefits**

Historic resources are finite and cannot be replaced, making them precious commodities that many buyers seek. Therefore, preservation adds value to private property. Numerous national studies document where local historic districts are established, property values typically rise or at least are stabilized. In this sense, designation of a district appears to help establish a climate for investment. Property owners within the districts know the time and money they spend on improving their properties will be matched with similar efforts on surrounding lots; these investments will not be undermined by inappropriate construction next door.

The condition of neighboring properties also affects the value of one's own property: people invest in a neighborhood as much as the individual structure itself and, in historic and conservation districts where investment is attracted, property owners recognize that each benefits from the commitment of their neighbors. An indication of the success of historic preservation is that the number of designated districts across the country has increased, due to local support, such that an estimated 1,000,000 properties, both as individual landmarks and in historic districts, are under local jurisdictions.

Preservation projects also contribute more to the local economy than do new building programs because each dollar spent on a preservation project has a higher percentage devoted to local labor and less to the purchase of materials. By contrast, new construction typically has a higher percentage of each dollar spent devoted to materials that are produced outside of the local economy. Therefore, when money is spent on rehabilitating a building, it has a higher "multiplier effect," keeping more money circulating in the local economy.

Depending on the extent of work needed, rehabilitating a historic building can cost less than constructing a new one. In fact, the guidelines for rehabilitation of historic structures presented in this document promote cost-saving measures. They encourage smaller and simpler solutions, which in themselves provide savings. Preserving building elements that are in good repair is preferred, for example, rather than replacing them. This typically is less expensive. In some instances, appropriate restoration procedures *may* cost more than less sensitive treatments. In such cases, property owners are compensated for this extra effort, to some extent, in the added value that historic district designation provides.

## **Incentives for preservation**

While these economic benefits are substantial, special incentives also exist to help offset potential added costs of appropriate rehabilitation procedures. Income tax credits are offered at the federal level, investment tax credits and property tax incentives are offered at the state level for appropriate rehabilitation. Contact the city historic preservation planner for more information regarding these incentives.

### **Responsibility of ownership**

Ownership of a historic property carries both the benefits described above and also a responsibility to respect the historic character of the property and its setting. While this responsibility does exist, it does not automatically translate into higher construction or maintenance costs. In the case of new construction, for example, these design guidelines focus on *where* a building should be located on a site and what its basic scale and character should be. The guidelines do *not* dictate the style of the new building or the degree of detail that it should have, factors which could affect building costs. (In fact, imitating historic styles is discouraged in these design guidelines.) Ultimately, residents and property owners should recognize that historic preservation and neighborhood conservation are long-range community policies that promote economic well-being and overall viability of Bozeman at large and that they play a vital role in helping to implement that policy through careful stewardship of the area's historic resources.

# Appendix D

## A. Historic Overview of the City of Bozeman

(Courtesy of the Gallatin Historical Society)

Prior to the Lewis and Clark Expedition in 1805, the Gallatin Valley was a favored hunting ground for migratory bands of Indians. As the century progressed, trappers and explorers continued to use Bozeman Pass as a gateway to the Missouri River Basin.

It was not until the discovery of gold in Bannack and Virginia City in the early 1860's that the Gallatin Valley began to experience significant change. When the gold in the west bank was found to be unsatisfactory, miners began looking for new ways to find their fortunes. Among the disappointed miners was John Bozeman. A Georgian by birth, Bozeman, like the legendary Jim Bridger, had turned to guiding immigrant trains to the gold fields by passing on the east side of the Big Horn Mountains, over the plains and west through Bozeman Pass, dropping into the Gallatin Valley and then southwest to Bannack. John Bozeman soon realized that more gold lay in the fertile soil of the Gallatin Valley than in either mining or guiding. While passing through the valley in 1863, Bozeman met two men, William J. Beall and Daniel E. Rouse, who had spent an unsuccessful year near Gallatin City trying to farm the poor soil. Bozeman arranged with Beall and Rouse to lay out a townsite the following spring when he planned to return with another immigrant train. That townsite would become Bozeman, Montana.



*Bozeman Main Street - Ellen Theater patrons in line in front of Chambers-Fisher store.  
(Courtesy of Gallatin Historical Society.)*



*623 North Tracy residence. (Courtesy of Gallatin Historical Society.)*

William Beall and Daniel Rouse laid out the townsite with Main Street as the major east-west axis and Rouse and Bozeman Avenues as the north-south cross streets. In 1870 W. W. DeLacy surveyed the townsite and it was formally platted, as was Rouses’s First Addition adjacent to the east of the townsite. Main Street was platted to be 93 feet wide to conform to the existing buildings and all other streets were to be 60 feet wide. The townsite covered forty acres and adjoining landowners agreed to donate enough ground for streets and alleys in order to “preserve the symmetry and uniformity of the town.”

Developers in the early years of the 1870s – before the economic depression of the middle and late seventies set in – optimistically filed new plats, expanding mostly to the southeast to higher and drier ground. During this time William Alderson touted his new Fairview Addition as the fashionable place to live and made Central (Willson) Avenue extra generous in width. Hoffman’s Addition and Park Addition were platted soon after. Park Addition was owned by Nelson Story, Walter Cooper and John S. Dickerson. Two strips of land were taken from the tracts and set aside for a park, later called Cooper Park. Later additions to the north were platted in anticipation of the railroad depot. These developments were plotted in the swampy northeast area that other residents had avoided. The new developments were not fast growing, and were used mostly as industrial sites. The lure of the depot could not lessen the mire of mud and swamp.

Bozeman boosters believed that their city might have a chance to become the site for Montana’s state capital. In anticipation of the capital election in 1892, an addition aptly named Capitol Hill was platted in 1890. The same year the Butte Addition was platted. By that time all additions, with the exception of two in the northwest corner of the survey area, were formally platted.

From 1864 to 1950 Bozeman's architecture and urban development underwent a series of transformations. Certain growth patterns were established well before the turn of the century, influenced by available materials, and prevailing technology and custom. When viewed within a historical context these changes, and those which followed, represent Bozeman's shifting patterns of social, economic and cultural relationships with local, regional and national events and conditions.

For purposes of examining Bozeman's architectural resources within their historical context, the community's development is presented here in five phases: the Townsite Phase, Village Phase, Civic Phase, Progressive Phase and Nationalization Phase.

### **Townsite Phase 1864-1872**

Bozeman's Townsite Phase may be defined as the period immediately following the origination of the townsite, brought on by the need for a supply center for the newly booming mining camps of Montana Territory. The period is characterized by the discovery and initial development of agricultural and timber resources, which promised stability for the settlement in light of uncertainties associated with transportation and supply routes through Indian territory. Although a few architecturally precocious structures were built during the Townsite Phase, most buildings were constructed of simple materials and by simple methods; log and wood frame buildings predominated. Commercial and industrial structures commanded attention and manpower, thus establishing early the importance of commerce and agricultural manufacturing to the future of the community.

### **Village Phase 1873-1885**

The Village Phase represents for Bozeman the beginnings of urbanization, and culminated in the arrival of the transcontinental railroad and incorporation of the City of Bozeman. The economic base became secure enough to sustain more permanent structures: including churches, schools and public buildings. While many Victorian commercial buildings were constructed of brick, industrial buildings continued to be constructed of wood, and distinctive frame residences of the Carpenter Gothic builders' tradition were prevalent. Sawn ornament in the Carpenter Gothic mode was utilized as an integrative element in rural vernacular house forms. The commercial and industrial potential of Bozeman and the surrounding area emerged as sufficient for continued growth.

### **Civic Phase 1884-1912**

The Civic Phase corresponds to the city's development as a regional center. Much of the development of this time relates to the attainment of social and economic diversity in the form of the Agricultural College, improved transportation networks, expanded city services and public utilities and fledgling industries related to agricultural and mineral resources. Victorian Revival architecture built during the Civic Phase encompassed Victorian Gothic, Romanesque revival, Ruskinian Gothic, Queen Anne and Colonial Revival. Eclecticism and individualism characterized both commercial and residential architecture, even when house pattern books were the source of designs.

### **Progressive Phase 1913-1929**

Bozeman's Progressive Phase was a period of transformation in relation to emerging twentieth century business and professional values. Growth continued steadily as before, but the nature of growth distinguished the Progressive Phase from earlier periods. City governance and politics were transformed by adoption of the Commission-Manager form of government. The Agricultural College increasingly attracted a population which, in accord with national trends, was sympathetic to efficiency and modernization in government as well as in other sectors, such as business and agriculture. Other twentieth century phenomena such as the automobile and tourism changed the face of Bozeman. Newer buildings were built in Arts and Crafts or Mission styles. Civic organizations mediated social and economic change as Bozeman weathered fluctuations in conditions prior, during and following World War I.

### **Nationalization Phase 1930-1950**

The Nationalization Phase represents Bozeman's emergence into the national milieu associated with the Great Depression, the New Deal, World War II and the post-war eras. The influence of the Agricultural College in the state's rural counties increased dramatically, leading to expansion of all three phases of the institution: research, instruction and extension. Military science and engineering vied with agriculture and other traditional concerns of the land grant college as war and economic transformation made their mark on the institution. New forms of communication and entertainment, such as radio and the "talkies," altered social patterns in Bozeman, just as the New Deal and later national events altered economic, political, administrative and cultural patterns. Idealization of national industrial culture took architectural form in Art deco and Moderne styles based on the industrial age. Simultaneously, the contrast between such urban ideals and the natural setting of Bozeman enhanced the community's appeal to residents and visitors alike.



*Bozeman Main Street, with freight wagons loaded with sacked wheat, circa 1905. (Courtesy of Gallatin Historical Society.)*

## B. Architectural Styles

As well as providing a visual link to Bozeman’s history, the architectural heritage creates a strong “sense of place.” In order to maintain the architectural history of Bozeman it is important to understand the specific styles and characteristics that were utilized throughout the city’s history.

This section provides a brief overview of various historic styles found in the city. While this section makes reference to a wide range of styles found here, it is not exhaustive. Certain architectural styles may exist that are not included in this section.

Property owners should review these descriptions carefully. In many cases the design guidelines make reference to the characteristics of styles presented in this chapter. In some cases, specific design guidance is included in the style description, depending on the prevalence of the style being described. For example, the section on Bungalows provides special guidance because the bungalow is a prevalent building type in many historic districts in Bozeman.

The homeowner is encouraged to use the styles section in analyzing the overall historic character of his/her building, as well as distinguishing its character-defining features. Ultimately, this should aid the home-owner in choosing an appropriate design solution for any proposed work.

### Architectural Styles Table of Contents

	Page
Settlement Vernacular	App-12
Log and Frame	App-12
Picturesque Styles	App-13
Gothic Revival	App-13
Italianate	App-14
Second Empire	App-15
Victorian Styles	App-16
Victorian Eclectic	App-16
Queen Anne	App-17
Revival Styles	App-18
Colonial Revival	App-18
Dutch Colonial Revival	App-18
Neo-Classical	App-19
Bungalow Styles	App-20
Modernist Styles	App-21
International Style	App-21
Art Deco	App-22
Post-War Cottage	App-23



*This traditional home and barn represent the agricultural and architectural beginnings of Bozeman, Montana. (Courtesy of Gallatin Historical Society)*



*The residence of General L.S. Willson was the first building erected in Bozeman. (Courtesy of Gallatin Historical Society)*

## Settlement Vernacular

### Log and Frame (c. 1860)

In the early history of Bozeman the buildings were mainly log and timber construction as a result of the timber resources available in the area. The first structures, and many of the subsequent buildings associated with the agricultural tradition of Bozeman, are wood construction. They are also typically simple forms reflecting function rather than a specific style or era.

Today characteristics of log and frame building can be seen throughout Bozeman in its historic barns and farmsteads and several early log homes.

### Characteristics:

- simple shed, gable or hipped roof forms
- limited openings for entrances and windows
- one story structures
- wood construction

## Picturesque Styles

### c. 1865-1885

Nationally, Picturesque styles — especially the Gothic Revival and the Italianate — represented in part a rejection of the Greek Revival, which was seen as being too discordant with the landscape and not easy to remodel, especially for additions. During the 1830s, a group of influential reformers called for a house style that would reinforce righteous living, that would help shore up Americans in the face of social upheaval caused by westward expansion and industrialization. Reformers wrote about residential architecture in terms of morality, and different styles were described as dishonest or honest. Locally, residents might have been aware of the theory behind the promotion of these styles, but it is more likely they represented something fashionable that was newly available. The use of the Picturesque styles including Gothic Revival, Italianate and Second Empire brought Bozeman citizens a little closer to the American mainstream despite their physical isolation.

#### Gothic Revival (c. 1865-1880)

The Gothic Revival style was quite popular circa 1880 amongst the early, wealthy residents of Bozeman. Examples of a rustic Gothic Revival can be seen in images of the residences of Walter Cooper, W. W. Alderson and M. M. Black, all influential residents of Bozeman. In a broader context, Gothic Revival was part of the Romantic movement that valued emotion over rational thought. As a rejection of classicism the most vocal proponent of this style, Andrew Jackson Downing, emphasized vertical lines, deep colors and the use of applied ornament. Few such homes exist in Bozeman's historic districts, but because this style is so unique in this area they greatly contribute to the architectural texture and richness of the city.

#### Characteristics:

- steeply pitched roof
- cross gable roof plan, or
- side gable roof plan with central cross gable over the door
- clapboard siding
- quoins
- decorative barge board along eaves of main gables and dormers
- two-over-two, double-hung sash windows
- pediments over windows
- bay windows
- lancet windows
- elaborate porch railings: turned posts, cut-out boards



*Gothic Revival residence c. 1893 (Courtesy of Gallatin Historical Society)*



*Gothic Revival residence (Courtesy of Gallatin Historical Society)*



*Gothic Revival Church*



*Italianate Residence c. 1885 (Courtesy of Gallatin Historical Society)*



*Italianate Commercial Building*



*Italianate Commercial Building - upper facade.*

### **Italianate (c. 1870-1895)**

The Italianate style was introduced by Andrew Jackson Downing in his 1850 publication, *The Architecture of Country Houses*. He extolled the virtues of the Gothic Revival, but offered the “villa,” a version based on Italian country houses that veered more toward classicism and did not have the religious overtones of the Gothic Revival. The style was used in Bozeman between 1882, the W. H. Tracy residence, and 1891, The J. H. Taylor residence, but it was not widely used and few examples remain.

#### **Characteristics:**

- brick, wood clapboard, plaster
- double-hung, narrow windows, often with round arch heads
- window panes are either one-over-one or two-over-two
- protruding sills
- ornate treatment of the eaves, including the use of brackets, modillions and dentil courses
- low-pitched, hipped roof
- blocky, cube shape, with a side-passage plan, or cross-gable
- bay windows, often rectangular shape
- quoins
- bay windows
- cresting
- transom, often curved, above the front door
- ornate porch treatment, with round columns or square posts, and bargeboard ornament



*Italianate Commercial Building*

## Second Empire (c. 1870-1890)

The Second Empire refers to the French reign of Louis Napoleon, the grand-nephew of Napoleon Bonaparte, who ruled from 1852 to 1870. In both France and America, the Second Empire style coincided with a period of prosperity and materialism, and was associated with urbanity and cosmopolitan society. In many cities in the United States it was used for government structures, but it was popular for residences as well. Classical details, such as quoins, round columns and heavy friezes were often used; however, there was usually so much going on that Second Empire buildings, at least high-style examples, took on a life of their own. Second Empire was seen in grand historic structures such as the Nelson Story residence, c. 1885, and “The Castle,” (both of which have been destroyed). Second Empire can also be seen in houses in Bozeman. These were generally constructed of brick and wood, and thus do not have the rich, sculptural wall texture found in examples in other parts of the country. Instead, builders and architects achieved the exuberance of this style by using asymmetrical and complicated massing and by applying plenty of ornament: cresting, railings, and moldings.

### Characteristics:

- steeply pitched, mansard roof
- roof can be either straight or concave, and is interrupted by dormers
- complex massing forms
- brick, stucco or wood clapboard
- wrought-iron ornament, such as cresting on roof or heavy, ornate fencing
- wide eaves, often with modillions
- corbelled chimney
- dormers with heavy moldings
- double-hung windows, either one-over-one or two-over-two lights
- hood moldings over the windows
- sandstone foundation, porch steps



*Second Empire Residence c. 1885 (Courtesy of Gallatin Historical Society)*



*Second Empire Residence*



*Victorian Eclectic residence*



*Victorian Eclectic residence*

## **Victorian Styles c. 1870-1910**

Technically the word “Victorian” refers to the long reign of Queen Victoria, which lasted from 1833 to 1901 and encompassed the rich variety of architectural styles that were popular during the nineteenth century. Architecturally the word “Victorian” evokes the complexity and irregularity seen in the massing and materials of modest homes to large mansions. The use of Victorian era styles in Bozeman became popular in the late nineteenth century.

Specific styles popular during this period are discussed below. The majority of Bozeman’s “Victorian” houses do not represent pure examples of anything; simply describing a house built in Bozeman after 1890 as “Victorian” can be misleading because residents and builders tended to take elements from one style and mix it with another. Still, among most Bozeman residents the term conjures up the image of a house built about 1890, either one or two story, with an asymmetrical form, a steeply-pitched roof and “lots of gingerbread.”

### **Victorian Eclectic (c. 1885-1910)**

Victorian Eclectic is not a specific style, but rather a conglomeration of elements of Victorian architecture that are combined to create a single structure. It often has a massing defined by a central cube with a hipped roof from which a shallow gabled wing projects. A multitude of examples of the one-story form can be seen throughout Bozeman, but many two-story examples can be found as well.

#### **Characteristics:**

- simple asymmetrical massing
- gable or hipped roof over the main block; projecting wing with front-facing gable
- porch with shed roof on one-story; often a gable on two-story examples
- turned columns
- tripartite division of windows on projecting wing
- bay windows and double-hung sash, made of wood
- horizontal siding can be seen on the first story and shingles are used on the second.
- common combination is the use of stone for the foundation, the use of fired brick on the walls, and wooden shingles in the gable ends.
- fancy scroll cut wood work, especially around gables and porches.
- ornamental brick work, such as corbelling and rows of soldiers bricks as lintels on masonry examples

### Queen Anne (c. 1885-1905)

Proponents of the Queen Anne style found their inspiration from the medieval art and architecture that preceded its namesake's reign (1702-1714), growing out of recognition of vernacular, modest, pre-industrial structures and a desire to bring about a close relationship of architecture and ornament.

In the United States, it developed from a desire to identify a national style. Both the Centennial Exposition, held in Philadelphia in 1876, and the popularity of New England coastal towns exposed Americans to their colonial, vernacular architectural past. The wood clapboard and shingle houses that were constructed in eastern Massachusetts during the seventeenth and early eighteenth centuries brought about the usual longing of security and simplicity that earlier ages always evoke, and were all the more appealing because they were seen as pure "American." The new Queen Anne style used the broad gables, long sloping roofs and small pane windows of these early houses for the exterior, while giant hearths, inglenooks and spacious, inviting halls influenced interior design. The style introduced a new kind of open planning and a new way of massing volumes of space; it was inherently eclectic and became available to homeowners of all income levels.

#### Characteristics:

- irregular, asymmetrical massing, through the use of a cross-wing floor plan and roofs with a variety of planes and slopes
- use of bay windows, towers, turrets, dormers, gables — anything that protrudes from the wall and the roof
- use of varying wall textures, horizontal siding can be seen on the first story and shingles are used on the second.
- common combination is the use of stone for the foundation, the use of fired brick on the walls, and wooden shingles in the gable ends.
- use of ornament: wooden scroll work on porches and gables, complicated brick patterns, ornate metal railings
- a large, plate-glass window with a fixed transom, often with leaded or stained glass, is commonly used in the front of the house, sometimes flanked by narrower windows that are usually in a one-over-one configuration.
- palladian windows are frequently in the gable ends.
- bay windows and double-hung sash, made of wood
- fancy scroll cut wood work, especially around gables and porches
- ornamental brick work, such as corbelling and rows of soldiers bricks as lintels on masonry
- turned porch columns
- tall brick chimneys
- wrought or cast iron as cresting along ridge lines or as railings and fencing



*Victorian Detail*



*Queen Anne Victorian*



*Queen Anne Victorian Detail*



*Colonial Revival (Courtesy of the Gallatin Historic Society)*



*Colonial Revival*



*Dutch Colonial Revival*

## Revival Styles

### Colonial Revival (c. 1890-1940)

“Colonial Revival” encompasses many variants of residential architecture used from about the turn of the century through the 1930s, and was especially popular during the teens. It can apply to a Georgian Revival mansion, a Neo-classical home, a Dutch Colonial house or a structure in which elements of several of these styles were used. With the exception of the Neoclassical, which was generally reserved for mansions, period revival styles lent themselves well to designs for modest homes and offered an alternative to the bungalow. Developers and builders found that evoking a cozy image of the past sold well, and that revival styles satisfied the need of home buyers to conform to tradition while making use of contemporary convenience and floor plans, such as the “L-shaped” living room.

### Dutch Colonial Revival (c. 1890-1915)

The examples shown at the right portray a style known as “Dutch Colonial Revival,” because of the use of a gambrel roof. This style is closely allied with the Shingle and the Queen Anne styles. The details, such as the window pattern, porches and materials are very similar.

#### Characteristics:

- gambrel roof. Both side-and front-facing variations can be found.
- shingle gable end
- two story
- prominent front porch, with classically-detailed porch supports and plain balustrades
- double-hung sash windows, with either single panes or multiple panes in the upper light.
- lunette windows in the upper gable
- large, single pane windows with a fixed transom on the first story



*Dutch Colonial Revival*



*Dutch Colonial Revival*

### **Neo-Classical (c. 1895-1925)**

This style is based on Greek or Roman order. They are almost always symmetrical and have classical details, such as dentil moldings, pediments over the doorways and round columns.

#### **Characteristics:**

- full-height porch with a pediment, round columns with complex capitals. In some instances the porches are curved porticoes.
- hipped roofs
- eaves with dentils, modillions, prominent frieze
- shutters
- panelled doors surrounded by pilasters and a pediment
- double-hung windows; usually one-over-one, but sometimes six-over-six or six-over one
- low porch rails with turned balusters

Many public buildings, such as the Carnegie Library building, the National Bank of Gallatin Valley and many other commercial buildings along Main Street exhibit elements of Revival Styles.



*Neo-Classical*



*Neo-Classical*



*Bungalow*



*Bungalow*



*Arts and Crafts Style Bungalow*



*Bungalow with Cobble Porch*

## **Bungalow Styles c. 1905-1925**

The word “bungalow” denotes a type rather than a style. It is believed that the word comes from a type of East Indian dwelling with broad verandas. Its immense popularity in the United States springs from a rejection of the constraints of the Victorian era, from the Arts and Crafts movement, and from the fact that it lent itself well to both modest and impressive house designs.

Although bungalows display a variety of materials and details, they are easily recognized by their wide, low-pitched roofs and broad front porches that create a deep, recessed space. Many bungalows fall readily into the Arts and Crafts categories, with exposed brackets and rafters, the use of “art” glass in windows and the combination of different textures, such as cobblestone and shingles. Others represent scaled-down Prairie-style versions, with low-pitched roofs, broad eaves and simple geometric shapes that provide an overall horizontal appearance.

A number of Craftsman Style Bungalows seen in Bozeman originated in pattern books and were modest, functional homes. Many of these can be seen along South Tracy. Although these homes are not unique to Bozeman, they represent an important era in the city’s architectural development, continuing to evoke their original intent: comfortable, informal living.

### **Characteristics:**

- a rectangular plan with one or two stories
- different roof types: a steeply pitched roof with the ridge line parallel to the street that covers a porch extending the full width of the house and hip-roofs with a shallow pitch
- exposed rafters, brackets — anything to evoke the structural composition of the building
- brick, wood shingle or clapboard siding
- broad eaves
- thick, tapered porch posts
- rectangular bay windows
- casement windows
- large, plate glass windows
- small paned windows, frequently seen in attic windows, in transoms and in the upper sashes of single hung windows.
- wing walls from the porch
- dormers that follow the line of the roof
- use of cobblestone
- concrete cap around porch wall
- both sandstone and concrete foundations were historically used on bungalows. Concrete foundations generally extend one to two inches beyond the wall
- doors are wooden with panels and windows in the upper third.

## Modern Styles

### c. 1930-1940

The modern styles discussed below derive their origin from a variety of sources, but overall the impetus to the “modern” styles was generated by a rejection of all historical references. Proponents of modernity did not differ from reformers of other eras in their desire to use design to address social issues, but they distinguished themselves by shunning the past as well as cultural or national contexts. Additionally, modern architects stressed the emphasis on volume and the inherent value and elegance of materials. Architects had new structural options, primarily the steel frame and reinforced concrete, so that flat roofs, greater window space and cantilevered elements could be used. They embraced new technology and “the machine age,” and their imprint has had a profound effect on American architecture and urbanism.

#### International Style (c. 1930-1940)

The use of the words “international style” refers to the title of the exhibit promoted by the Museum of Modern Art in New York City in 1931 presenting the work of forty architects from fifteen countries. It has become synonymous with modern styles and post-World War II architecture.

#### Characteristics:

- flat roofs
- an emphasis on volume, rather than mass, most often expressed through an extensive use of glass and angular, horizontal shapes
- asymmetrical facades
- corner windows
- metal casement windows, often with small panes.
- metal pipes used for balusters
- no surface ornamentation
- an attempt to create smooth wall surfaces



*Modern Building Downtown*



*International Style Residence*



*Art Deco Building*

## **Art Deco** **c. 1925-1940**

The Art Deco style is often characterized by linear, geometric compositions emphasizing verticality. Windows and material relief are also used to reinforce the geometric composition of the facade. The material palette of this style is often stone, metal, and glass.

### **Characteristics**

- geometric forms, with a combination of rounded corners and angular shapes
- stepped or setback facade elements
- use of metal sash windows with small panes
- references to abstract natural motifs such as a sunrise
- horizontal bands at the cornice, referred to as “speed bands”



*Art Deco Building*



*Art Deco Building*

## **Post-War Cottage**

### **c. 1930-1950**

The Post-War Cottage (sometimes referred to as a “Cape Cod cottage” or a “World War II-Era cottage”) is often considered as a sub-category of the Colonial Revival. They mark a transition between the Colonial Revival examples constructed before the war and the ubiquitous ranch type homes built afterwards. Because of their relatively recent construction many people have a difficult time thinking of them as “historic,” but in most instances they have met the fifty-year mark establishing significance, and their distinctive characteristics (listed below) make these buildings worthy of a sensitive and appropriate preservation approach.

#### **Characteristics:**

- brick, shingles or wood clapboard
- panelled door, surrounded by pilasters and an entablature
- small entrance porch with round columns with a simple capital
- double-hung windows, often with six-over-six lights
- multi-pane metal sash windows
- shutters
- dormers on front roof slope



*Typical Post-War Cottage*

# APPENDIX E

## Definitions

**Alignment.** The arrangement of objects along a straight line.

**Appurtenances.** An additional object added to a building; typically includes vents, exhausts hoods, air conditioning units, etc.

**Asphalt Shingles.** A type of roofing material composed of layers of saturated felt, cloth or paper, and coated with a tar, or asphalt substance, and granules.

**Baluster.** A short, upright column or urn-shaped support of a railing. (Figure 1)



Fig. 1

**Balustrade.** A row of balusters and the railing connecting them. Used as a stair rail and also above the cornice on the outside of a building. (Figure 1)

**Bargeboard.** A projecting board, often decorated, that acts as trim to cover the ends of the structure where a pitched roof overhangs a gable. (Figure 2)



Fig. 2

**Board and Batten.** Vertical plank siding with joints covered by narrow wood strips.

**Bracket.** A supporting member for a projecting element or shelf, sometimes in the shape of an inverted L and sometimes as a solid piece or a triangular truss. (Figure 3)



Fig. 3

**Building.** A resource created principally to shelter any form of human activity, such as a house.

**Clapboards.** Narrow, horizontal, overlapping wooden boards, usually thicker along the bottom edge, that form the outer skin of the walls of many wood frame houses. The horizontal lines of the overlaps generally are from four to six inches apart in older houses.

**Column.** A slender upright structure, generally consisting of a cylindrical shaft, a base and a capital; pillar: It is usually a supporting or ornamental member in a building. (Figure 4)



Fig. 4

**Composition Shingles.** See asphalt shingles.

**Conservation Area.** Conservation areas are typically used in newer areas or older areas with less integrity where historic district designation is not feasible. Maintaining overall character is the focus.

**Coping.** The protective uppermost course of a wall or parapet. (Figure 5)



fig. 5

**Cornice.** The continuous projection at the top of a wall. The top course or molding of a wall when it serves as a crowning member. (Figure 6)

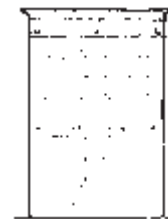

fig. 6

**Door frame.** The part of a door opening to which a door is hinged. A door frame consists of two vertical members called jambs and a horizontal top member called a lintel or head.

**Double-Hung Window.** A window with two sashes (the framework in which window panes are set), each moveable by a means of cords and weights. (Figure 7)

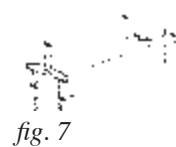

fig. 7

**Dormer.** A window set upright in a sloping roof. The term is also used to refer to the roofed projection in which this window is set.

**Eave.** The underside of a sloping roof projecting beyond the wall of a building. (Figure 8)



fig. 8

**Elevation.** A mechanically accurate, “head-on” drawing of a face of a building or object, without any allowance for the effect of the laws of perspective. Any measurement on an elevation will be in a fixed proportion, or scale, to the corresponding measurement on the real building.

**Facade.** Front or principal face of a building, any side of a building that faces a street or other open space.

**Fascia.** A flat board with a vertical face that forms the trim along the edge of a flat roof, or along the horizontal, or “eaves,” sides of a pitched roof. The rain gutter is often mounted on it. (Figure 9)

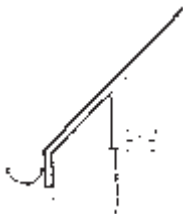

fig. 9

**Fenestration.** The arrangement of windows and other exterior openings on a building.

**Form.** The overall shape of a structure (i.e., most structures are rectangular in form).

**Frame.** A window component. See window parts.

**Gable.** The portion, above eave level, of an end wall of a building with a pitched or gambrel roof. In the case of a pitched roof this takes the form of a triangle. The term is also used sometimes to refer to the whole end wall.

**Glazing.** Fitting glass into windows and doors.

**Head.** The top horizontal member over a door or window opening. (Figure 10)

**Historic District.** A geographically definable area of urban or rural character, possessing a significant concentration or continuity of site, building, structures or objects unified by past events or aesthetically by plan or physical development.

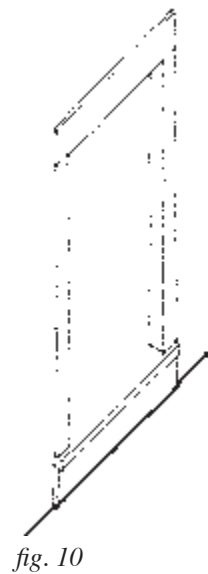

**Historic House or Resource.** A structure or streetscape that is unique to its period of significance and as such is to be wisely managed for the benefit of present and future generations.

**In-Kind Replacement.** To replace a feature of a building with materials of the same characteristics, such as material, texture, color, etc.

**Integrity.** A property retains its integrity, if a sufficient percentage of the structure dates from the period of significance. The majority of a building's structural system and materials should date from the period of significance and its character defining features also should remain intact. These may include architectural details, such as dormers and porches, ornamental brackets and moldings and materials, as well as the overall mass and form of the building.

**Landmark.** Any of the following which have a special historical, architectural, cultural, aesthetic or engineering interest or value of a historical nature:

1. An individual structure or portion thereof;
2. An integrated group of structures on a single lot;
3. A site, or portion thereof; or
4. Any combination thereof.

**Lap Siding.** See clapboards.

**Mass.** The physical size and bulk of a structure.

**Masonry.** Construction materials such as stone, brick, concrete block or tile.

**Material.** As related to the determination of “integrity” of a property, material refers to the physical elements that were combined or deposited in a particular pattern or configuration to form a historic resource.

**Module.** The appearance of a single facade plane, despite being part of a larger building. One large building can incorporate several building modules.

**Molding.** A decorative band or strip of material with a constant profile or section designed to cast interesting shadows. It is generally used in cornices and as trim around window and door openings. (Figure 11)

**Muntin.** A bar member supporting and separating panes of glass in a window or door.

**Opaque Fence.** A fence that one cannot see through. (Figure 18)

**Orientation.** Generally, orientation refers to the manner in which a building relates to the street. The entrance to the building plays a large role in the orientation of a building; whereas, it should face the street.

**Panel.** A sunken or raised portion of a door with a frame-like border.

**Parapet.** An upward extension of a building wall above the roofline, sometimes ornamented and sometimes plain, used to give a building a greater feeling of height or a better sense of proportion. (Figure 12)

**Pediment.** A triangular section framed by a horizontal molding on its base and two sloping moldings on each of its sides. Usually used as a crowning member for doors, windows and mantles. (Figure 13)

**Period of Significance.** Span of time in which a property attained the significance.

**Porch Piers.** Upright structures of masonry which serve as principal supports for porch columns. (Figure 14)

**Post.** A piece of wood, metal, etc., usually long and square or cylindrical, set upright to support a building, sign, gate, etc.; pillar; pole. (Figure 15)



fig. 11



fig. 12



fig. 13

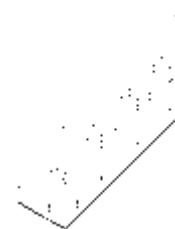

fig. 14



fig. 15

**Preservation.** The act or process of applying measures to sustain the existing form, integrity and materials of a building or structure, and the existing form and vegetative cover of a site. It may include initial stabilization work, where necessary, as well as ongoing maintenance of the historic building materials.

**Protection.** The act or process of applying measures designed to affect the physical condition of a property by defending or guarding it from deterioration, or to cover or shield the property from danger of injury. In the case of buildings and structures, such treatment is generally of a temporary nature and anticipates future historic preservation treatment; in the case of archaeological sites, the protective measure may be temporary or permanent.

**Reconstruction.** The act or process of reproducing by new construction the exact form and detail of a vanished building, structure or object, or part thereof, as it appeared at a specific period of time.

**Rehabilitation.** The act or process of returning a property to a state of utility through repair or alteration which makes possible an efficient contemporary use while preserving those portions or features of the property which are significant to its historical, architectural and cultural value.

**Renovation.** The act or process of returning a property to a state of utility through repair or alteration which makes possible a contemporary use.

**Restoration.** The act or process of accurately recovering the form and details of a property and its setting as it appeared at a particular period of time by means of the removal of later work or by the replacement of missing earlier work.

**Sash.** See window parts.

**Scale.** The size of structure as it appears to the pedestrian.

**Semi-Transparent Fence.** A fence that one can see partly through. (Figure 18)

**Shape.** The general outline of a building or its facade.

**Side Light.** A usually long fixed sash located beside a door or window; often found in pairs. (Figure 16)

**Siding.** The narrow horizontal or vertical wood boards that form the outer face of the walls in a traditional wood frame house. Horizontal wood siding is also referred to as clapboards. The term “siding” is also more loosely used to describe any material that can be applied to the outside of a building as a finish.



*fig. 16*

**Sill.** The lowest horizontal member in a frame or opening for a window or door. Also, the lowest horizontal member in a framed wall or partition.

**Size.** The dimensions in height and width of a building's face.

**Stile.** A vertical piece in a panel or frame, as of a door or window.

**Stabilization.** The fact or process of applying measures designed to reestablish a weather resistant enclosure and the structural stability of an unsafe or deteriorated property while maintaining the essential form as it exists at present.

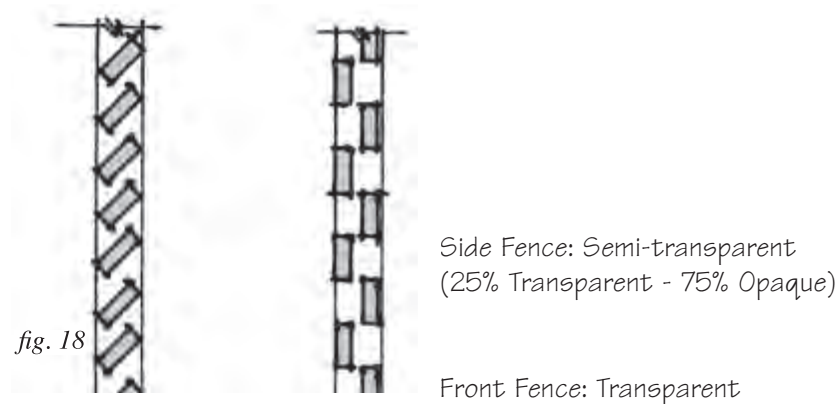

fig. 17

**Streetscape.** Generally, the streetscape refers to the character of the street, or how elements of the street form a cohesive environment.

**Transom Window.** A small window or series of panes above a door, or above a casement or double hung window. (Figure 17)

**Transparent Fence.** A fence that one can see through. (Figure 18)



**Vernacular.** This means that a building does not have details associated with a specific architectural style, but is a simple building with modest detailing and form. Historically, factors often influencing vernacular building were things such as local building materials, local climate and building forms used by successive generations.

**Visual Continuity.** A sense of unity or belonging together that elements of the built environment exhibit because of similarities among them.

**Window Parts.** The moving units of a window are known as sashes and move within the fixed frame. The sash may consist of one large pane of glass or may be subdivided into smaller panes by thin members called muntins or glazing bars. Sometimes in nineteenth-century houses windows are arranged side by side and divided by heavy vertical wood members called mullions.